

**International Studies Program
Working Paper 11-24
December 2011**

**The Dynamics of Revenue-Neutral
Trade Liberalization**

**Jenny E. Ligthart
Gerard C. van der Meijdenz**



**International Studies Program
Working Paper 11-24**

**The Dynamics of Revenue-Neutral Trade
Liberalization**

**Jenny E. Lighthart
Gerard C. van der Meijdenz**

December 2011

International Studies Program
Andrew Young School of Policy Studies
Georgia State University
Atlanta, Georgia 30303
United States of America

Phone: (404) 651-1144
Fax: (404) 651-4449
Email: ispaysps@gsu.edu
Internet: <http://isp-aysps.gsu.edu>

Copyright 2006, the Andrew Young School of Policy Studies, Georgia State University. No part of the material protected by this copyright notice may be reproduced or utilized in any form or by any means without prior written permission from the copyright owner.

International Studies Program Andrew Young School of Policy Studies

The Andrew Young School of Policy Studies was established at Georgia State University with the objective of promoting excellence in the design, implementation, and evaluation of public policy. In addition to two academic departments (economics and public administration), the Andrew Young School houses seven leading research centers and policy programs, including the International Studies Program.

The mission of the International Studies Program is to provide academic and professional training, applied research, and technical assistance in support of sound public policy and sustainable economic growth in developing and transitional economies.

The International Studies Program at the Andrew Young School of Policy Studies is recognized worldwide for its efforts in support of economic and public policy reforms through technical assistance and training around the world. This reputation has been built serving a diverse client base, including the World Bank, the U.S. Agency for International Development (USAID), the United Nations Development Programme (UNDP), finance ministries, government organizations, legislative bodies and private sector institutions.

The success of the International Studies Program reflects the breadth and depth of the in-house technical expertise that the International Studies Program can draw upon. The Andrew Young School's faculty are leading experts in economics and public policy and have authored books, published in major academic and technical journals, and have extensive experience in designing and implementing technical assistance and training programs. Andrew Young School faculty have been active in policy reform in over 40 countries around the world. Our technical assistance strategy is not to merely provide technical prescriptions for policy reform, but to engage in a collaborative effort with the host government and donor agency to identify and analyze the issues at hand, arrive at policy solutions and implement reforms.

The International Studies Program specializes in four broad policy areas:

- Fiscal policy, including tax reforms, public expenditure reviews, tax administration reform
- Fiscal decentralization, including fiscal decentralization reforms, design of intergovernmental transfer systems, urban government finance
- Budgeting and fiscal management, including local government budgeting, performance-based budgeting, capital budgeting, multi-year budgeting
- Economic analysis and revenue forecasting, including micro-simulation, time series forecasting,

For more information about our technical assistance activities and training programs, please visit our website at <http://isp-aysps.gsu.edu> or contact us by email at ispaysps@gsu.edu.

The Dynamics of Revenue-Neutral Trade Liberalization*

Jenny E. Ligthart[#]

Tilburg University

University of Groningen

CAMA-Canberra and CESifo-Munich

Gerard C. van der Meijden[‡]

Tilburg University

December 2011

Abstract

The paper studies the dynamic welfare and macroeconomic effects of a revenue-neutral strategy of offsetting tariff reductions with increases in destination-based consumption taxes. To this end, we employ a dynamic general equilibrium model of a small open developing economy, featuring endogenous labor supply and sector-specific capital and land. In contrast to conventional results from tax-tariff reform studies based on fixed factor endowments, we find that instantaneous utility and the volume of trade fall on impact. Aggregate output rises in the short run, reflecting increased labor supply and a more efficient allocation of resources across sectors. In the long run, however, aggregate output declines, whereas instantaneous utility and the volume of trade increase compared to the pre-reform equilibrium. For a plausible calibration of the model, lifetime welfare is shown to increase.

JEL codes: F13, F41, H20

Keywords: Tariff reform, coordinated tax-tariff reform, consumption tax reform, trade liberalization

*We are grateful for helpful comments from Ben Heijdra and Steve Turnovsky. We also benefited from discussions with participants at the workshop on Public Finance and Macroeconomic Dynamics (Groningen, September 2011), the 26th Congress of the European Economic Association (Oslo, August 2011), the 67th conference of the International Institute of Public Finance (Ann Arbor, August 2011), the FACT Tax Workshop (Tilburg University, June 2011), the Development Economics Workshop (Tilburg University, April 2011), and a seminar at Utrecht University (July 2011).

[#]Corresponding author: Department of Economics and CentER, Tilburg University, P.O. Box 90153, 5000 LE Tilburg, The Netherlands, Phone: +31-13-466-8755, Fax: +31-13-466-3042, E-mail: j.ligthart@tilburguniversity.edu

[‡]Department of Economics and CentER, Tilburg University, P.O. Box 90153, 5000 LE Tilburg, The Netherlands, Phone: +31-13-466-8978, Fax: +31-13-466-3042, E-mail: g.c.vdrmeijden@tilburguniversity.edu

1 Introduction

During the last two decades, the World Bank and the International Monetary Fund (IMF) have strongly advocated trade liberalization programs in developing countries. However, although tax collections on imports in low-income countries have decreased from 5.4 percent of Gross Domestic Product (GDP) in 1985 to 3 percent in 2005, trade taxes continue to be an important source of revenue for governments of developing economies.¹ In 2005, tariff revenue accounted for 18 percent of total government revenue in low-income countries compared to less than 1 percent in OECD countries (World Bank, 2010). Policy advice of Washington-based international financial institutions has stressed the importance of introducing compensating tax measures to recoup the revenue losses from trade liberalization. Much of the discussion has focused on a broad-based consumption tax, such as the value-added tax (VAT), as an alternative source of revenue. However, very little is known about the intertemporal macroeconomic and welfare consequences of these consumption tax *cum* tariff reforms, an issue that will be taken up in this paper.

Early theoretical contributions to the literature of piecemeal tariff reform do not pay much attention to the revenue effects of tariff cuts (e.g. Hatta, 1977; and Fukushima, 1979), whereas revenue losses are an important source of distress for governments in developing countries (Baunsgaard and Keen, 2010). More recent studies (e.g., Michael et al., 1993; Hatzipanayotou et al., 1994; Abe, 1995; Keen and Ligthart, 2002; and Kreckemeier and Raimondos-Møller, 2008) acknowledge the government budget constraint and specify conditions under which tax-tariff reforms yield a (static) net efficiency gain. That is, the production efficiency gain induced by the tariff rate cut more than offsets the consumption efficiency loss caused by the increase in the consumption tax rate.² So far, little attention has been paid to the potential efficiency gains in a dynamic context. Naito (2006a-b) and Ligthart and Van der Meijden (2010) are notable exceptions. Taking dynamics and forward-looking behavior into account is essential because integrated tax-tariff reforms affect intertemporal relative prices, causing instantaneous utility and allocation effects to differ considerably over time. Moreover, the existing static literature ignores labor market implications and persistently assumes a

¹We use the World Bank classification of low-income countries, which includes 33 countries in 2011.

²The efficiency gain of coordinated tax-tariff reform does not always hold up when allowance is made for important features of reality such as a hard-to-tax informal sector (Emran and Stiglitz, 2005) and imperfect competition on the goods market (Keen and Ligthart, 2005).

fixed endowment of production factors. Naito (2006a-b) and Ligthart and Van der Meijden (2010)—to which our work is related—model capital accumulation, but assume exogenous labor supply.³ Therefore, these studies cannot address the labor market implications of the reform. Factor accumulation and the endogeneity of labor supply, however, are features of reality that have an important bearing on the welfare effects of tax-tariff reforms.

This paper analyzes the welfare and dynamic allocation effects of an integrated tax-tariff reform that leaves the path of government revenue unaffected. To this end, we develop a micro-founded dynamic macroeconomic model of a small open developing economy. We focus on a country that cannot affect world market prices because 67 percent of 33 low-income countries—for which data are available—have an average degree of openness exceeding 50 percent during the 2002–2008 period.⁴ Furthermore, the static tax-tariff reform literature has primarily studied small open economies. We solve the model analytically and analyze the main qualitative effects of the tax-tariff reform graphically. To quantify the allocation and welfare effects of the reform, we calibrate the model for a typical developing country—using plausible parameters from the data and the literature—and conduct a numerical simulation. We are one of the first to provide quantitative evidence on revenue-neutral tax tariff reforms.⁵

Building on Brock and Turnovsky (1993), our model features two final goods sectors, that is, an agricultural export sector and an import-competing manufacturing sector. Agricultural goods and manufacturing goods are modeled as imperfect substitutes in consumption. Both sectors employ a sector-specific input (i.e., land in the agricultural sector and physical capital in the manufacturing sector) and use intersectorally mobile labor. Forward-looking households supply labor endogenously and are infinitely lived. Our preference specification allows an intertemporal substitution effect on labor supply—via changes in household wealth—which is important for shock propagation (cf. Prescott, 2006, p. 385) and is also found to be of non-negligible size in empirical studies (cf. Kimball and Shapiro, 2008). Finally, the government provides lump-sum transfers to households, which are funded by a mix of pre-existing taxes

³Both papers use quite different modeling frameworks and reform scenarios. Using an endogenous growth model with goods trade, Naito (2006a-b) studies the growth effects of tax-tariff reforms that are revenue neutral only in a present-value sense. Ligthart and Van der Meijden (2010) employ an overlapping generations model with an informal sector to study the revenue and intergenerational welfare effects of a price-neutral tax-tariff reform.

⁴Openness is defined as the sum of exports and imports expressed as a percentage of GDP. The average degree of openness in a sample of 33 low-income countries during 2002-2008 amounted to 66 percent.

⁵The tax-tariff reform literature is primarily theoretical in nature. The regression analysis of Baunsgaard and Keen (2010) and the numerical simulations of Naito (2006a-b) are one of the few quantitative contributions.

and import tariffs.

To take into account that changes in the physical capital stock are costly and do not occur instantaneously, we postulate adjustment cost of investment at the level of the firm. However, financial capital is assumed to be perfectly mobile. In line with the tax-tariff reform literature, we do not model any frictions and/or imperfections on labor markets and goods markets (e.g., a dual labor market or an informal sector), which are typical of developing countries.⁶ In this way, we preclude adding too many deviations from the standard framework at once so that we can isolate the ramifications of relaxing the assumption of a static world with fixed factor endowments. In addition, we keep our model stylized, which allows us to ‘inspect the mechanism’ behind our comparative dynamic results (cf. Turnovsky, 2011). Our model is small enough to be able to obtain a fair share of the results analytically and to provide a graphical analysis.

We find that the reform increases aggregate output and employment in the short run, owing to households increasing their labor supply in response to the foreseen fall in their human capital. In the long run, however, aggregate output and employment decrease, reflecting a decline in the stock of physical capital. Output and employment in the import-substitution sector fall, whereas output and employment in the export sector rise, more so in the long run than in the short run. The gross volume of trade (so-called market access) falls in the short run and increases in the long run. Because of the rise in labor supply, instantaneous utility falls on impact, causing the short-run welfare implications to differ from that found in the static literature. Instantaneous utility recovers during the transition period, eventually yielding a higher long-run level than before the reform. For a plausible calibration, lifetime utility is shown to increase, reflecting an increase in leisure consumption. Compared to the case of a fixed labor endowment, endogenous labor supply reduces the size of the lifetime welfare increase, the more so the larger the intertemporal elasticity of labor supply. In terms of welfare losses, the harmfulness of the tariff rate on imported consumption goods increases with the size of the substitution elasticities between factors of production in both sectors.

The paper is structured as follows. Section 2 sets out the model for a small open developing country. Section 3 solves the model analytically and Section 4 summarizes the

⁶Notable exceptions are Haque and Mukherjee (2005) and Keen and Ligthart (2005), who analyze the implications of firms’ market power on goods markets, and Emran and Stiglitz (2005) and Ligthart and Van der Meijden (2011), who model an informal sector.

model graphically. Section 5 studies the macroeconomic dynamics of tax-tariff reform for a plausible calibration of the model. Finally, Section 6 concludes the paper.

2 The Model

This section describes our dynamic macroeconomic model for a typical small open developing economy. The modeling framework allows endogenous labor supply and physical capital accumulation and thereby goes beyond the basic tax-tariff reform framework based on fixed factor endowments.⁷ Subsequently, we discuss household, firm, and government behavior.

2.1 Households

The infinitely-lived representative household, which is endowed with perfect foresight, allocates one unit of its time in each period between working and leisure. Instantaneous utility is derived from private consumption and leisure according to a logarithmic specification. Lifetime utility as of time t is given by

$$\Lambda(t) \equiv \int_t^\infty [\varepsilon \ln C(z) + (1 - \varepsilon) \ln(1 - L(z))] e^{-\rho(z-t)} dz, \quad 0 < \varepsilon < 1, \quad (1)$$

where $C(z)$ and $L(z)$ denote ‘composite’ consumption and labor supply in period z , respectively, ρ represents the pure rate of time preference, and ε is the utility weight of private consumption. Equation (1) allows a wealth effect on labor supply, which is common in business cycle models (cf. King et al., 1988) and dynamic macro models more generally (cf. Heijdra, 1998).⁸ Following Backus et al. (1994), the index of composite consumption is described by a constant elasticity of substitution (CES) specification

$$C(z) = \left[\gamma C_M(z)^{\frac{\sigma_C - 1}{\sigma_C}} + (1 - \gamma) C_E(z)^{\frac{\sigma_C - 1}{\sigma_C}} \right]^{\frac{\sigma_C}{\sigma_C - 1}},$$

where $C_M(z)$ and $C_E(z)$ are consumption of the manufacturing good and the agricultural good, respectively, $0 < \sigma_C \ll \infty$ is the elasticity of substitution between the two commodities, and $0 < \gamma < 1$ determines their relative weight. By choosing a CES sub-utility function, we

⁷Compared to the static tax-tariff reform literature, our consumption side is simplified by focusing on two consumption goods rather than many.

⁸Some business cycle studies, however, use Greenwood et al. (1988) preferences in which case the wealth effect on labor supply is eliminated.

are able to explore the empirically relevant case of σ_C smaller than unity (Dennis and Iscan, 2007). The flow budget constraint of the household is:

$$\dot{A}(z) = rA(z) + (1 - t_L)w(z) + T(z) - X(z), \quad (2)$$

where r is the world market real rate of interest, $A(z)$ denotes real financial wealth, t_L is an exogenously given tax on labor income, $w(z)$ is the real wage rate, $T(z) > 0$ are lump-sum government transfers, $X(z)$ is ‘full’ consumption, and a dot above a variable indicates a time derivative (e.g., $\dot{Y}(z) \equiv dY/dz$).⁹ We define full consumption as the sum of total expenditure on consumption and the opportunity costs of leisure

$$X(z) \equiv p(z)C(z) + w(z)(1 - t_L)[1 - L(z)], \quad (3)$$

where $p(z)$ is the ‘ideal’ price-index of composite consumption

$$p(z) = \Omega_p \left[\gamma [(1 - \gamma)p_M(z)]^{1-\sigma_C} + (1 - \gamma) [\gamma p_E(z)]^{1-\sigma_C} \right]^{\frac{1}{1-\sigma_C}},$$

with $\Omega_p \equiv [\gamma(1 - \gamma)]^{-1} > 0$ and $p_M(z)$ and $p_E(z)$ denoting the domestic consumer prices of the manufacturing and the agricultural good. The world market prices of both consumption goods are exogenously given and normalized to unity. We choose the agricultural commodity as the numeraire. The domestic consumer prices are then a function of the government’s tax instruments only

$$p_M(z) = (1 + t_C(z))(1 + \tau_M(z)), \quad p_E(z) = 1 + t_C(z), \quad (4)$$

where $\tau_M(z)$ is an *ad valorem* import tariff on the imported good and $t_C(z)$ is a destination-based (*ad valorem*) consumption tax, which is levied upon the tariff-inclusive import price. In line with IMF policy advice (cf. IMF, 2011) and a fair share (53 percent) of existing VAT systems (cf. Ebrill et al., 2001), a single tax rate applies to both consumption goods. Having only a single rate of VAT considerably reduces both tax compliance and administration costs,

⁹We also could have chosen to include government expenditures in the utility function instead of using lump-sum transfers. Given that we study revenue-neutral reforms, the two approaches are equivalent.

which is important for developing countries with typically weak administrative capacities.¹⁰

Because of the time-separable specification of the lifetime utility function, the optimization problem of the household can be solved in two stages. In the first stage, the representative household chooses time paths for $C(z)$ and $L(z)$ to maximize lifetime utility (1) subject to its flow budget constraint (2). In the second stage, composite consumption is divided between consumption of the two commodities. The first stage of the optimization problem gives rise to the following two optimality conditions:

$$\frac{1 - \varepsilon}{\varepsilon} \frac{C(z)}{1 - L(z)} = \frac{(1 - t_L)w(z)}{p(z)}, \quad (5a)$$

$$\frac{\dot{X}(z)}{X(z)} = \frac{\dot{C}(z)}{C(z)} + \frac{\dot{p}(z)}{p(z)} = r - \rho, \quad (5b)$$

$$\lim_{z \rightarrow \infty} A(z)e^{-r(z-t)} = 0. \quad (5c)$$

Equation (5a) sets the marginal rate of substitution between consumption and leisure equal to the relative price of the two. Equation (5b) is a standard Euler equation showing that full consumption growth is proportional to the difference between the real rate of interest and the pure rate of time preference. Equation (5c) is the No-Ponzi-Game solvency condition. The first equality in (5b) uses (3) and (5a), which together imply that expenditures on composite consumption and on leisure are fixed fractions of full consumption:

$$p(z)C(z) = \varepsilon X(z), \quad (1 - t_L)w(z)[1 - L(z)] = (1 - \varepsilon)X(z).$$

Because of the small open economy assumption, the interest rate is exogenously given and fixed, so that the condition $r = \rho$ needs to be imposed for a steady state to exist. Intuitively, the economy would keep accumulating assets—and cease being small in world capital markets—if $r > \rho$ or be depleting assets if $r < \rho$. It follows from the Euler equation that the time profile of full consumption is flat. By integrating (2) and using $r = \rho$, we find that full consumption is a constant fraction of total wealth,

$$X(z) = \rho [A(z) + H(z)], \quad (6)$$

¹⁰By employing a single consumption tax rate we deviate from the static tax-tariff reform literature, which assumes that changes in different tariff rates on different goods are compensated by changes in differential tax rates on consumption goods. Obviously, the latter specification is of much less practical value.

where $H(z)$ denotes human capital, which is defined as the after-tax present discounted value of the household's time endowment:

$$H(t) \equiv \int_t^\infty [(1 - t_L)w(z) + T(z)] e^{-r(z-t)} dz. \quad (7)$$

The second stage of the household's optimization problem yields demand functions for manufacturing goods and agricultural goods:

$$C_M(z) = \gamma^{\sigma_C} \left(\frac{p_M(z)}{p(z)} \right)^{-\sigma_C} C(z), \quad C_E(z) = (1 - \gamma)^{\sigma_C} \left(\frac{p_E(z)}{p(z)} \right)^{-\sigma_C} C(z).$$

Commodity demand depends on relative goods prices, the elasticity of substitution between manufacturing goods and agricultural goods, aggregate consumption, and the preference weight given to each commodity.

2.2 Firms

We consider a production structure roughly resembling that of a typical developing economy, consisting of an agricultural export sector and a manufacturing import-substitution sector. There are three factors of production, that is, labor, land, and physical capital.¹¹ Both sectors deploy labor—which is perfectly mobile across sectors—and a sector-specific factor. Land is specific to the export sector and physical capital is specific to the import-substitution sector. Capital goods are imported and are not being produced domestically.

Firms in the import-substitution sector produce the manufactured good according to an iso-elastic production function:

$$Y_M(z) = \Omega_M \left[\alpha_M K(z)^{\frac{\sigma_M - 1}{\sigma_M}} + (1 - \alpha_M) L_M(z)^{\frac{\sigma_M - 1}{\sigma_M}} \right]^{\frac{\sigma_M}{\sigma_M - 1}}, \quad 0 < \sigma_M \ll \infty, \quad (8)$$

where $\Omega_M > 0$ is a productivity index, $K(z)$ represents physical capital, $L_M(z)$ is employment in the import-substitution sector, σ_M denotes the elasticity of substitution between physical capital and labor, and $0 < \alpha_M < 1$ determines the importance of physical capital in production. We normalize the world market price of imported capital goods to unity, so

¹¹Imported intermediate goods play an important role in developing countries. Although we do not formally model intermediate inputs, capital can be thought of being defined in a broad sense, including intermediates.

that the domestic producer price for capital goods equals

$$p_I(z) = 1 + \tau_I,$$

where τ_I denotes an exogenously given *ad valorem* import tariff on capital goods. Following Uzawa (1969), the firm faces a strictly concave accumulation function:

$$\dot{K}(z) = \left[\Psi \left(\frac{I(z)}{K(z)} \right) - \delta \right] K(z), \quad \Psi(0) = 0, \quad \Psi'(\cdot) > 0, \quad \Psi''(\cdot) < 0, \quad (9)$$

where $\Psi(\cdot)$ denotes the installation cost function, $\delta > 0$ is the constant rate of capital depreciation, and $I(t)$ denotes gross investment. The degree of physical capital immobility is given by $\chi_K \equiv -(I/K)\Psi''/\Psi' > 0$, where a small χ_K characterizes a high degree of capital mobility. Note that the limiting case of $\chi_K \rightarrow 0$ (i.e., no adjustment costs) corresponds to perfect capital mobility.

The firm chooses time profiles for employment and investment to maximize the discounted value of its cash flows:

$$V_K(t) \equiv \int_t^\infty [(1 + \tau_M(z))Y_M(z) - w(z)L_M(z) - (1 + \tau_I)I(z)] e^{-r(z-t)} dz,$$

subject to the production function (8) and the accumulation equation (9). The firm takes the real wage rate and the initial stock of physical capital as given. The conditions characterizing the optimum are:

$$w(z) = [1 + \tau_M(z)][1 - \theta_K(z)] \frac{Y_M(z)}{L_M(z)}, \quad (10a)$$

$$1 + \tau_I = q(z)\Psi' \left(\frac{I(z)}{K(z)} \right), \quad (10b)$$

$$\frac{\dot{q}(z) + [1 + \tau_M(z)]\theta_K(z) \frac{Y_M(z)}{K(z)}}{q(z)} = r + \delta - \left[\Psi \left(\frac{I(z)}{K(z)} \right) - \Psi' \left(\frac{I(z)}{K(z)} \right) \frac{I(z)}{K(z)} \right], \quad (10c)$$

$$\lim_{z \rightarrow \infty} q(z)K(z)e^{-r(z-t)} = 0, \quad (10d)$$

where $\theta_K(z)$ is the output elasticity of physical capital and $q(z)$ denotes Tobin's q , which measures the market value of physical capital relative to its replacement costs. Condition (10a) set the real wage rate equal to the marginal product of labor. By equating marginal

cost and marginal revenue of investment, (10b) gives investment demand. The evolution of Tobin's q over time is determined by equation (10c), which equates the return on physical capital—consisting of the sum of the change in Tobin's q and the marginal product of capital—with the user cost of physical capital.¹² Equation (10d) is the transversality condition for the firm's optimization problem.

Firms in the export sector produce the agricultural good according to:

$$Y_E(z) = \Omega_E \left[\alpha_E Z^{\frac{\sigma_E - 1}{\sigma_E}} + (1 - \alpha_E) L_E(z)^{\frac{\sigma_E - 1}{\sigma_E}} \right]^{\frac{\sigma_E}{\sigma_E - 1}}, \quad 0 < \sigma_E \ll \infty, \quad (11)$$

where $\Omega_E > 0$ is a productivity index, Z represents the fixed factor land, $L_E(z)$ is employment in the export sector, σ_E denotes the substitution elasticity between land and labor, and $0 < \alpha_E < 1$ determines the importance of land in production. Profit maximization gives rise to the following two first-order conditions:

$$\begin{aligned} w(z) &= [1 - \theta_Z(z)] \frac{Y_E(z)}{L_E(z)}, \\ r_Z(z) &= \theta_Z(z) \frac{Y_E(z)}{Z}, \end{aligned}$$

where $\theta_Z(z)$ is the output elasticity of land and $r_Z(s)$ denotes the rental rate on land. The government is not able to tax rents on land, because of the lack of clear property titles, which is a widespread problem in developing countries (cf. De Soto, 2001).

2.3 Government

The government's objective is to raise an exogenously given amount of revenue at each instant of time, which is employed to provide lump-sum transfers to households. Because the government does not have access to lump-sum taxes and land rental taxes, the government finances its spending by the following menu of distortionary taxes: tariffs on imported final consumption and investment goods, taxes on domestic consumption, and taxes on labor income.¹³ We abstract from the corporate income tax in view of its small revenue share

¹²Without adjustment costs, we have $\Psi(\cdot) = I(z)/K(z)$, which yields $\chi_K = 0$. Equation (10b) then reduces to $q(z) = 1 + \tau_M$. In this case, $q(z)$ and $K(z)$ adjust instantaneously to their steady-state levels. Consequently, equation (10c) collapses to $\frac{1 + \tau_M(z)}{1 + \tau_I} \frac{\partial Y_M(z)}{\partial K(z)} = r + \delta$, which is the familiar rental rate derived in a static framework.

¹³Since there are no externalities associated with the production of the manufactured good, tariffs are not motivated by an infant industry argument, but are only employed by the government to raise revenue.

in developing countries. For simplicity, and following most of the literature, we assume a hundred percent compliance rate for all taxes.¹⁴ Then, the budget identity of the government is given by:

$$T(z) = t_C(z) [C_E(z) + (1 + \tau_M(z))C_M(z)] + t_L w(z)L(z) + \tau_M(z) [C_M(z) - Y_M(z)] + \tau_I I(z). \quad (12)$$

The first term on the right-hand side represents consumption tax revenue and the second term captures revenue generated by the labor income tax. The third and fourth term denote revenue from the tariffs on the imported consumption good and the capital good, respectively.

2.4 Foreign Sector

The relative world market prices are chosen such that our small open model economy imports part of the manufacturing goods that are being consumed domestically and exports part of the domestically produced agricultural goods. Because capital goods are not produced domestically, aggregate imports are given by $IM(z) = C_M(z) + I(z) - Y_M(z)$. Exports are equal to the difference between domestic production and consumption of the agricultural good: $EX(z) = Y_E(z) - C_E(z)$. Accordingly, the trade balance is given by $TB(z) = Y_E(z) + Y_M(z) - C_E(z) - C_M(z) - I(z)$. The current account of the balance of payments is equal to income from net foreign assets plus the trade balance: $\dot{F}(z) = rF(z) + TB(z)$, where $F(z)$ denotes the stock of net foreign assets. The intertemporal budget constraint for the economy is given by:

$$F(t) = - \int_t^\infty TB(z) e^{-r(z-t)} dz,$$

which requires the discounted flow of future trade balance deficits to equal the current stock of net foreign assets.

¹⁴Most developing countries are better at collecting import duties than consumption taxes. One may then argue that switching from a tax with high compliance to one with low compliance may require a higher consumption tax rate to maintain revenue neutrality. However, 55 percent of gross VAT revenue is collected at the border (Ebrill et al. 2001), which alleviates the effect of the compliance cost differential. Furthermore, our numerical analysis is based on data taking into account the effect of tax evasion on tax collections. See Turnovsky and Basher (2009) for an analysis of tax enforcement in a two-sector developing country.

2.5 Macroeconomic Equilibrium

Because of a perfectly elastic supply of manufactured goods, any domestic excess demand for these goods can always be met on the world market. Wage flexibility implies that labor supply by the representative household equals aggregate labor demand by firms in the two production sectors: $L(z) = L_M(z) + L_E(z)$. Production at factor costs should equal spending: $Y(z) = Y_M(z) + Y_E(z) = C_M(z) + C_E(z) + I(z) + TB(z)$.

Financial market equilibrium implies that $A(z) = V_K(z) + V_Z(z) + F(z)$, where $V_K(z) = q(z)K(z)$ denotes the stock market value of import-competing firms and $V_Z(z)$ is the value of the stock of land. Because all financial assets are assumed to be perfect substitutes, arbitrage ensures that the evolution of the value of land satisfies

$$rV_Z(z) = \dot{V}_Z(z) + r_Z(z)Z.$$

This condition requires that the return on land—consisting of the sum of the capital gain or loss $\dot{V}_Z(z)$ and rental income from land $r_Z(z)Z$ —equals the return on assets.

3 Solving the Model

We derive the log-linearized reduced-form dynamic model and subsequently analyze its stability. All technical details are relegated to the Appendix.

3.1 Reduced-Form Model

We log-linearize the model of Section 2 around an initial steady state (Table 1). Tildes ($\tilde{\cdot}$) denote relative changes from the initial steady state for most variables (e.g., $\tilde{X}(z) \equiv dX(z)/X_0$), where X_0 denotes the initial steady-state value of full consumption. Exceptions are financial variables and human wealth (e.g., $\tilde{A}(z) \equiv rdA(z)/Y_0$), lump-sum transfers (e.g., $\tilde{T}(z) \equiv dT(z)/Y_0$), and tax and tariff rates (e.g., $\tilde{t}_C(z) \equiv dt_C(z)/(1 + t_{C0})$ and $\tilde{\tau}_M(z) \equiv d\tau_M(z)/(1 + \tau_{M0})$). Time derivatives of variables are generally defined as $\dot{\tilde{X}}(z) \equiv d\dot{X}(z)/X_0$, except for the time derivative of financial wealth and human capital (e.g., $\dot{\tilde{A}}(z) \equiv rd\dot{A}(z)/Y_0$). We assume that t_L and τ_I remain constant. The log-linearized model can be condensed to a four dimensional system of linear first-order differential equations. The dynamic system consists of two predetermined variables, $\tilde{K}(z)$ and $\tilde{F}(z)$, and two forward-looking variables,

$\tilde{q}(z)$ and $\tilde{X}(z)$. All endogenous variables of the model can be expressed in terms of these state variables and the tax policy variables (Appendix A.1).

The method of log-linearization does not allow us to study large shocks. Hence, we study a piecemeal cut in tariffs on consumption goods rather a wholesale removal of those tariffs.¹⁵ The permanent and unanticipated cut in the import tariff rate on consumption goods (i.e., $\tilde{\tau}_M < 0$) causes an immediate change in government revenue.¹⁶ Moreover, during transition, government revenue is affected by changes in the tax and tariff bases. We adjust the consumption tax rate such that the revenue effects of the reform are neutralized at each instant of time. Consequently, the domestic consumption tax rate becomes time varying. To determine the time path of the consumption tax rate, we first express the change in government revenue [$\tilde{T}(z)$ from (T1.18)] as a function of the four state variables, the domestic consumption tax rate, and the consumption tariff rate (Appendix A.1). Subsequently, we impose $\tilde{T}(z) = 0$ and solve for the change in the consumption tax rate:

$$\tilde{t}_C(z) = -\frac{1}{\phi_{TC}} \left(\xi_{TK} \tilde{K}(z) + \xi_{TQ} \tilde{q}(z) + \xi_{TX} \tilde{X}(0) + \phi_{TM} \tilde{\tau}_M \right). \quad (13)$$

The ξ_{Tj} 's (for $j = \{K, Q, X\}$) reflect pure tax-tariff base effects of the reform and the ϕ_{Tl} 's (for $l = \{C, M\}$) capture both rate and base effects.

If initial tax and tariff rates are zero (i.e., $t_{C0} = t_{L0} = \tau_{I0} = \tau_{M0} = 0$), there are no tax and tariff base effects so that only the rate effects remain. Hence, $\xi_{TK} = \xi_{TQ} = \xi_{TX} = 0$, in which case (13) reduces to: $\tilde{t}_C(z) = -(\phi_{TC}/\phi_{TM})\tilde{\tau}_M > 0$. The term ϕ_{TC}/ϕ_{TM} is then unambiguously positive, so that a tariff rate cut induces a rise in the consumption tax rate. In this special case, the economy operates on the upward-sloping segment of the Laffer curve. Obviously, this result does not extend to all initial tax and tariff rates. High initial tax and tariff rates may cause a severe erosion of the consumption tax, labor income tax, and import tariff bases such that the economy ends up on the 'wrong side' of the Laffer curve. In our analysis, we set initial tax and tariff rates such that we find an equilibrium on the upward-sloping segment of the Laffer curve (see Section 5.1).

¹⁵Although a radial contraction of tariffs is theoretically interesting (cf. Hatzipanayotou et al., 1994), in practice, not many countries resort to such a strategy.

¹⁶The policy reform is unanticipated in the sense that the time of announcement and implementation of the policy change coincide. We normalize the time of the policy reform to zero.

3.2 Dynamic System and Stability

To simplify the analysis, we split the dynamic system into an investment subsystem and a savings subsystem. Collecting the variables of interest in vectors, we can write the state variables of the investment subsystem as $\tilde{\mathbf{P}}_I(z) \equiv [\tilde{K}(z), \tilde{q}(z)]^\top$ and the state variables of the savings subsystem as $\tilde{\mathbf{P}}_S(z) \equiv [\tilde{X}(z), \tilde{F}(z)]^\top$, where \top denotes a transpose. In the special case of exogenous labor supply, the model is recursive so that the investment subsystem can be solved completely independent of the savings subsystem. However, if labor supply is endogenous, we derive the solution to the investment subsystem conditional on $\tilde{X}(0)$. Subsequently, we solve the savings subsystem to obtain $\tilde{X}(0)$ and the time profile of $\tilde{F}(z)$. The dynamic equations describing the evolution of the economy are given by

$$\dot{\tilde{\mathbf{P}}}_I(z) = \Delta_I \tilde{\mathbf{P}}_I(z) + \Lambda_I [\tilde{X}(0), \tilde{\tau}_M]^\top, \quad (14a)$$

$$\dot{\tilde{\mathbf{P}}}_S(z) = \Delta_S \tilde{\mathbf{P}}_S(z) + \Lambda_S [\tilde{K}(z), \tilde{q}(z), \tilde{\tau}_M]^\top, \quad (14b)$$

where Δ_I and Δ_S denote the Jacobian matrices of the investment subsystem and savings subsystem, respectively:

$$\Delta_I \equiv \begin{bmatrix} 0 & \delta_{KQ} \\ \delta_{QK} & r \end{bmatrix}, \quad \Delta_S \equiv \begin{bmatrix} 0 & 0 \\ \delta_{FX} & r \end{bmatrix},$$

where the matrix elements $\delta_{KQ} > 0$, $\delta_{QK} > 0$, and $\delta_{FX} < 0$ are defined in Appendix A.2. Note that we have used (13) to eliminate $\tilde{t}_C(z)$ from (14a) and (14b). The matrices Λ_I and Λ_S on the right-hand side of (14a) and (14b) are given by

$$\Lambda_I \equiv \begin{bmatrix} 0 & 0 \\ \lambda_{QX} & \lambda_{QM} \end{bmatrix}, \quad \Lambda_S \equiv \begin{bmatrix} 0 & 0 & 0 \\ \lambda_{FK} & \lambda_{FQ} & \lambda_{FM} \end{bmatrix}, \quad (15)$$

where the matrix elements $\lambda_{QX} > 0$, $\lambda_{QM} < 0$, $\lambda_{FK} \leq 0$, $\lambda_{FQ} < 0$, and $\lambda_{FM} \geq 0$ are defined in Appendix A.2. The row of zeros in the first matrix of (15) indicates that $\tilde{X}(0)$ only affects the investment subsystem via the $\dot{\tilde{q}}(z)$ locus. The sign of λ_{FK} is ambiguous. On the one hand, there is a positive effect of a larger capital stock on net foreign asset accumulation via: (i) a higher level of output (direct effect); and (ii) a reduced import tariff base (indirect effect), requiring an increase in the consumption tax rate to keep the reform revenue neutral,

which in turn induces lower composite consumption. On the other hand, there is a negative effect of capital accumulation on net foreign asset accumulation: (i) directly through a rise in private investment; and (ii) indirectly via an expansion of the tariff base of imported capital goods. The latter enables the government to lower the consumption tax rate in a revenue-neutral fashion, which leads to higher composite consumption. The ambiguity of the sign of λ_{FM} originates from two opposing effects on net foreign assets induced by an increase of the import tariff rate: (i) a direct positive effect, reflecting an increase in output and a decrease in composite consumption; and (ii) an indirect negative effect through an increased labor income tax base. The latter enables the government to lower the consumption tax rate in a revenue-neutral fashion, which leads to higher composite consumption. Assumption 1, which holds for plausible parameter values, pins down the signs of λ_{FK} and λ_{FM} .

Assumption 1 *The direct output effect dominates the other effects, so that: (i) the effect of the capital stock on net foreign asset accumulation is positive (i.e., $\lambda_{FK} > 0$); and (ii) the effect of the import tariff rate on net foreign asset accumulation is positive (i.e., $\lambda_{FM} > 0$). A sufficient condition for (ii) to hold is $\sigma_{LL} > \frac{t_L}{1-t_L}$, where σ_{LL} is the labor supply elasticity.*

The steady state of the system is denoted by $\dot{\mathbf{P}}_I(z) = \dot{\mathbf{P}}_S(z) = 0$. Note that the knife-edge condition $r = \rho$ implies a zero root in full consumption; that is, the first row of Δ_S consists of zeros. Consequently, we obtain a hysteretic steady state. The stability properties of the model are summarized in Proposition 1.

Proposition 1 *The dynamic system is locally saddle-point stable and features a hysteretic steady state. It can be decomposed in two subsystems—one for investment and one for savings—with the following properties:*

(i) *the investment subsystem has two distinct real eigenvalues; that is, $-h_1^* < 0$ and $r_1^* = r + h_1^* > 0$ with $\partial h_1^*/\partial \chi_K < 0$, $\lim_{\chi_K \rightarrow 0} h_1^* = \infty$, and $\lim_{\chi_K \rightarrow \infty} h_1^* = 0$; and*

(ii) *the savings subsystem has two distinct real eigenvalues; that is, $h_2^* = 0$ and $r_2^* = r > 0$.*

Proof. See Appendix A.2. \square

4 Graphical Analysis

Section 4.1 develops a graphical apparatus and Section 4.2 uses this framework to analyze the allocation effects of the proposed tax-tariff reform.

4.1 Graphical Apparatus

Panel (a) of Figure 1 shows the phase diagram for the investment subsystem. The capital stock equilibrium (CSE) locus—given by $\dot{\tilde{K}}(z) = 0$ —represents combinations of $\tilde{K}(z)$ and $\tilde{q}(z)$ for which net investment is zero so that the capital stock is constant. It follows from (9) and (10b) that this only occurs if Tobin's q equals its steady-state value, implying that the CSE locus is horizontal at $\tilde{q} = 0$. If Tobin's q is above this line net investment will be positive, which is indicated by the horizontal arrows in the figure. The investment plan equilibrium (IPE) locus—given by $\dot{\tilde{q}}(z) = 0$ —gives combinations of $\tilde{K}(z)$ and $\tilde{q}(z)$ for which Tobin's q is constant over time. The IPE schedule is negatively sloped, because an increase in the capital stock depresses the marginal product of capital so that its value in equilibrium will be lower. For points to the right of the IPE schedule, the marginal product of capital is too low, so that part of the return to capital consists of capital gains. Conversely, for points to the left of the IPE schedule, the marginal product of capital is too high, giving rise to capital losses on investment. Hence, $\dot{\tilde{q}}(z) > 0$ to the right of the locus and $\dot{\tilde{q}}(z) < 0$ to the left, as represented by the vertical arrows in the figure. The arrow configuration for the CSE and IPE schedules confirms that the equilibrium at E_0 is saddle-point stable.

Panel (b) of Figure 1 represents graphically the savings subsystem. The condition $r = \rho$ ensures that $\dot{\tilde{X}}(z) = 0$ irrespective of $\tilde{F}(z)$ and $\tilde{X}(z)$. Hence, only the net foreign assets (NFA) locus—given by $\dot{\tilde{F}}(z) = 0$ —is drawn, which gives combinations of $\tilde{F}(z)$ and $\tilde{X}(z)$ that yield a constant stock of net foreign assets. The locus has a positive slope, because a higher steady-state level of full consumption can only be sustained if the stock of net foreign assets increases. For points above the line, full consumption is too high, so that net foreign assets decrease over time. Conversely, for points below the line, full consumption is too low, implying an increasing stock of net foreign assets.

4.2 Allocation Effects

We discuss the allocation effects of the revenue-neutral tax-tariff reform by using the phase diagrams in Panels (a) and (b) of Figure 1 and the labor market equilibrium in Figure 2.

Investment Subsystem Panel (a) of Figure 1 shows that the reform shifts the IPE locus down from $[\dot{q} = 0]_0$ to $[\dot{q} = 0]_1$. The capital stock locus remains unaffected. For a given capital stock, Tobin's q jumps down from E_0 to A, reflecting a decrease in the marginal product of capital. Two opposing effects are at work: a direct price effect and an indirect wealth effect. The direct price effect causes Tobin's q to fall via a lower producer price of manufactured goods. The indirect wealth effect positively affects Tobin's q through its impact on labor supply. Under plausible parameter values, the indirect wealth effect on the IPE locus falls short of the direct price effect (Assumption 2).¹⁷ Tobin's q recovers over time as the capital stock decreases during transition to the new equilibrium E_∞ . In the long run, Tobin's q is back at its initial value, but the capital stock is permanently lower.

Assumption 2 *The direct negative effect of the fall in the producer price p_M on the marginal product of capital dominates the potentially counteracting indirect effect operating through the wealth effect on labor supply: $|\lambda_{QM}\tilde{\tau}_M| > |\lambda_{QX}\tilde{X}|$.*

Savings Subsystem On impact, the tax tariff reform shifts the NFA curve upward if $\lambda_{FQ}\tilde{q}(0) + \lambda_{FM}\tilde{\tau}_M > 0$. Conversely, if $\lambda_{FQ}\tilde{q}(0) + \lambda_{FM}\tilde{\tau}_M < 0$, the NFA curve shifts down. Panel (b) of Figure 1 shows the case in which the NFA locus shifts upward from $[\dot{F} = 0]_0$ to $[\dot{F} = 0]_1$. Over time, as the capital stock decreases, the NFA locus shifts down, owing to declining aggregate output. Eventually, the NFA locus even shifts down beyond its initial position to $[\dot{F} = 0]_\infty$. Full consumption jumps to a point below $[\dot{F} = 0]_1$ and in all considered scenarios this point is also below E_0 . It follows that full consumption immediately falls as the economy jumps from E_0 to A. Subsequently, during transition, the stock of net foreign assets increases along the $[\dot{F} = 0]_\infty$ locus to reach a higher long-run value at E_∞ .

Labor Market Panels (a) and (b) of Figure 2 depict the labor demand schedules for the import-substitution sector and the export sector, respectively [see (T1.7)]. Panel (c) shows

¹⁷Although a formal proof is lacking, a numerical inspection did not yield any instances violating the assumption.

the aggregate (Frisch) labor supply curve together with the aggregate labor demand, which are given by (T1.5) and (T1.6), respectively. The cut in the import tariff on consumption decreases labor demand by firms in the import-substitution sector, which is represented by an inward shift in the labor demand schedule from $\tilde{L}_M^D(\tilde{K}_0, \tilde{\tau}_{M,0})$ to $\tilde{L}_M^D(\tilde{K}_0, \tilde{\tau}_{M,1})$ in Panel (a). The labor demand curve of firms in the export sector in Panel (b) remains unaffected. Hence, aggregate labor demand [see Panel (c)] shifts to the left. The aggregate labor supply curve shifts to the right, as a result of the wealth effect on labor supply; that is, households supply more labor because they experience a fall in wealth. On impact, workers relocate from the import-substitution sector to the export sector and the equilibrium wage rate falls. Employment in the export sector goes up immediately. The sign of the change in aggregate employment depends on the magnitude of the shift of the aggregate labor supply curve relative to that of the aggregate labor demand curve. The figure shows the case in which aggregate employment jumps up.

Over time, the labor demand curve of the import-substitution sector shifts further to the left as the capital stock decreases. Because the labor demand curve of the export sector remains unaffected again, the aggregate labor demand curve shifts leftward as well. Consequently, employment in the import-substitution sector and aggregate employment both decline over time. The decreasing capital stock—and the associated lower labor productivity—in the import-substitution sector ensures that workers relocate from the import-substitution to the export sector, boosting long-run employment in the export sector. In the long run, the wage rate is lower than before the reform. The sign of the change in long-run aggregate employment again depends on the magnitude of the shift of the aggregate labor supply curve (wealth effect) relative to that of the aggregate labor demand curve (productivity effect). The figure shows the case in which long-run aggregate employment goes down.

5 Numerical Analysis

To obtain insight into the quantitative allocation and welfare effects of the proposed revenue-neutral tax-tariff reform, Section 5.1 calibrates the model and Sections 5.2 and 5.3 perform a numerical simulation.

5.1 Calibration

We calibrate the model to match important characteristics of a typical developing open economy in the low-income group. Table 2 contains an overview of the calibration parameters. The tax and tariff rates are chosen such that the revenue shares of the tax instruments are in line with the data.¹⁸ The decade averages of the revenue shares of the consumption tax, labor income tax, and tariffs in total tax revenue are 48, 22, and 30 percent, respectively (World Bank, 2010). Given that final goods generally bear a higher tariff rate than capital goods, we impose a tariff rate on consumption goods of 15 percent and a tariff rate on capital goods of 7.5 percent. The implied consumption tax rate and labor income tax rate are 9 percent and 7 percent, respectively. The implied tax revenue-to-GDP share is 16 percent (Table 3), which is within the range of 14.1 to 16.7 percent that Gordon and Li (2009) report for low-income and middle-income countries, respectively.

In line with Gollin (2002), the labor income share in the import-substitution sector ($1 - \theta_K$) is set to 0.7. Following Valentinyi and Herrendorf (2008), the labor income share in agriculture ($1 - \theta_Z$) takes on a lower value than that of the aggregate economy, owing to a large land income share. We set the labor income share in the agricultural sector to 0.5. The parameter Z is chosen such that the employment share of the agricultural sector amounts to around 65 percent, which is the average for low-income countries over the last decade (World Bank, 2010).

Empirical estimates of the input substitution elasticities in production cover a wide range. Salhofer (2000) reviews studies on the substitution elasticity between land and labor and reports a weighted mean value of 0.3, with a standard deviation of 0.5. For the substitution elasticity between capital and labor, Chirinko (2008) concludes that it varies between 0.4 and 0.6. In view of these results, we set the substitution elasticity between land and labor to 0.3 and between capital and labor to 0.5.

We follow Mendoza (1995) by setting the rate of capital depreciation (δ) to 10 percent, but choose a rate of interest (r) of 5 percent, which is one percentage point above Mendoza's

¹⁸Because of exemptions, tax evasion, and the like, the collected tariff rate—defined as tariff revenue divided by the import value—is smaller than the statutory tariff rate. Our chosen tax and tariff rates are therefore lower bounds of actual statutory tax and tariff rates.

value. The concave adjustment cost function is assumed to have a logarithmic form:

$$\Psi\left(\frac{I}{K}\right) = \bar{z} \left[\ln\left(\frac{I}{K} + \bar{z}\right) - \ln \bar{z} \right],$$

where \bar{z} is a parameter that regulates the concavity of the function and therefore the magnitude of the adjustment costs. By choosing $\bar{z} = 2$, we obtain adjustment costs equal to 0.2 percent of GDP, which is slightly above Mendoza (1991), who works with a ratio of 0.1 percent of GDP for the Canadian economy.

The intertemporal substitution elasticity of labor supply (i.e., $\sigma_{LL} \equiv (1 - L_0)/L_0$) is equal to the so-called Frisch elasticity of labor supply. Using micro data, Kimball and Shapiro (2008) find estimates of the Frisch elasticity of about one. Real business cycles (RBC) studies (e.g., Mendoza, 1991; and Prescott, 2006), however, typically work with Frisch elasticities of at least two. We set $\sigma_{LL} \equiv (1 - L_0)/L_0 = 2.25$, which is in accordance with the RBC literature. Assuming a daily time endowment of 16 hours, $\sigma_{LL} = 2.25$ corresponds to 1,800 annual hours worked per worker.¹⁹ We set $\sigma_C = 0.5$, which is in line with the smaller than unitary elasticities found by Dennis and Iscan (2007). For the preference parameters γ and ε , we pick values to get an implied imports-to-GDP ratio of 41 percent, which is equal to the decade average in low-income countries (World Bank, 2010). We find an implied export-to-GDP ratio of 40 percent, which is considerably higher than the 10-year average share of manufacturing imports in GDP of 24 percent for low-income countries. The discrepancy is a result of the imposed current account equilibrium in the initial steady state.

Using World Bank (2010) data, gross fixed capital formation as a share of GDP was on average 19 percent in low-income countries during the last decade. Our implied investment-to-GDP ratio of 5 percent is considerably lower than this number, but does not seem unreasonable given that: (i) our model does not feature public investment; and (ii) investment is only possible in the import-substitution sector, where the investment-to-output ratio equals 18 percent. The implied share of consumption in GDP amounts to 92 percent, which is somewhat lower than the average share of 98 percent of household final consumption expenditure in GDP in low-income countries during the last decade.

¹⁹Although not much data for low-income countries are available, this number is close to the average of 1,821 annual hours worked per worker for the 13 countries with a per capita income below 15,000 US dollars (PPP-adjusted) in 2010 (The Conference Board, 2011)

5.2 Allocation Effects

Table 4 presents the short-run and long-run allocation effects of the reform. Three scenarios are being distinguished. The first scenario (labeled $\sigma_{LL} = 2.25$) presents the benchmark, which sets all parameter values in accordance with Table 2. In the second scenario (labeled $\sigma_{LL} = 0$), we investigate the case of exogenous labor supply to emphasize the importance of allowing endogenous labor supply in our benchmark case. Scenario three (labeled $\sigma_E = \sigma_M = 1$) restricts the production functions to a Cobb-Douglas specification, which is commonly used in the literature. We will first discuss the benchmark scenario and subsequently highlight the most important differences between scenarios.

Benchmark Scenario The wealth panel of Table 4 shows that households experience a fall in human capital, but enjoy an increase in the value of their financial wealth holdings in the short run as well as in the long run. Moreover, within their financial wealth portfolio a reallocation from investment in domestic capital toward foreign assets occurs in the long run. Because of the positive employment effect in the export sector, the value of land jumps up immediately and further increases over time.

The labor market panel of Table 4 shows—in line with our discussion in Section 4.2—that aggregate employment rises immediately. Intuitively, the reform induces an increase in labor supply induced by the negative wealth effect on labor supply, which is driven by the considerable fall in human capital. Over time, the wage rate decreases as the capital-labor ratio falls. Because labor and capital are cooperative factors, the fall in physical capital leads to a negative aggregate employment effect in the long run. Reallocation of workers from the import-substitution sector to the export sector increases employment in the latter sector, more so in the long run than in the short run. The immediate increase in aggregate employment leads to a rise in aggregate output, as shown in the production panel of Table 4. Moreover, the improved allocation of workers across sectors amplifies the initial positive effect on aggregate production. Qualitatively, the sectoral output responses are similar to the employment effects in both sectors.

Because households experience a wealth loss in the short run, they cut back on their consumption of both commodities immediately. Compared to the manufacturing good, consumption of the agricultural good goes down by more, owing to an increase in the relative

consumer price of agricultural goods. Over time, aggregate consumption increases because of a transitional decline in the consumption tax rate (see below). The long-run effect on consumption, however, remains negative. Market access, which is defined as the sum of imports and exports, decreases immediately as a result of the substantial fall in investment, but increases in the long run when both imports and exports are higher than before the reform.

To compensate for the tightening of all four tax bases and the tariff rate decline, the consumption tax rate has to rise in the short run. During transition, a broadening of both import tariff bases and the consumption tax base takes place, which dominates the revenue effect of the shrinking labor tax base, so that the required long-run increase in the consumption tax rate falls short of its short-run rise.

Exogenous Labor Supply The second scenario sets the elasticity of labor supply (σ_{LL}) to zero, so that the positive short-run effect and the negative long-run effect on employment disappear. As a result, the short-run fall in the real wage rate and in human capital are less pronounced than for $\sigma_{LL} > 0$ which, together with the downward jump in the price index, increase composite consumption in the short run. The jump in consumption broadens the consumption tax base, thereby yielding a smaller required increase in the consumption tax rate than in the benchmark scenario. The short-run increase in aggregate production can now be fully attributed to a more efficient allocation of a given stock of labor across the sectors. Combining (T1.10), (T1.11), (A.3), and (A.4), and using $\tilde{K}(0) = \sigma_{LL} = 0$, this can be shown by:

$$\frac{\tilde{Y}(0)}{\tilde{\tau}_M} = -\frac{\omega_L^M \omega_L^E}{|\Omega|} \frac{\tau_M}{1 + \tau_M}, \quad (16)$$

where ω_L^M and ω_L^E denote the GDP share of labor income in the import-substitution and export sector, respectively. Equation (16) is negative if $\tau_M > 0$ (because $|\Omega| > 0$, see Appendix A.1).

Because aggregate labor supply remains constant, capital decumulation will be less severe so that aggregate output decreases by a relatively smaller amount in the long run. The steady-state marginal product of capital is determined by the interest rate on the world market, which in turn—via the factor price frontier—determines the long-run capital-labor

ratio and the real wage rate. Therefore, the long-run fall in the real wage rate is not affected by the elasticity of labor supply [compare columns (2) and (4)]. Net foreign assets increase by less than in the benchmark scenario, reflecting a smaller fall in domestic investment.

Cobb-Douglas Specification Qualitatively, the responses to the reform do not change between the Cobb-Douglas scenario [see columns (5)–(6)] and the benchmark case. Imposing a unitary elasticity of substitution between factors of production basically amplifies the responses on the production side. The long-run effects on the stock of physical capital and output in the import-competing sector are noticeably larger than in the benchmark scenario. As a result, the tax base of the tariff on imported consumption goods increases substantially over time, leading to a large drop in the required long-run change in the consumption tax rate.

5.3 Welfare Effects

This section discusses the welfare effects of the revenue-neutral tax-tariff reform. In view of the exogenously imposed revenue requirement, the first-best outcome with zero tax and tariff rates cannot be achieved. In fact, the initial equilibrium is not even second best, given that the pre-existing tax and tariff rates are set such that they are representative of a typical developing economy. In this case, reducing one distortion does not necessarily improve welfare (Lipsey and Lancaster, 1957). The interactions between different distortions are complex, because the initial tax system does not only have static efficiency effects—by affecting relative goods prices and the relative price of consumption and leisure—but also lead to intertemporal distortions by influencing the investment decision of firms and the household’s intertemporal allocation of consumption and labor supply. To determine the sign of the welfare change induced by the reform, we conduct a numerical analysis. Before venturing into the numerical illustration, we first discuss our welfare measure.

By substituting (3) and (5a) into (1), lifetime utility of the representative household can be written as:

$$\Lambda(0) \equiv \int_0^\infty \ln \left[\frac{X(z)}{p_U(z)} \right] e^{-\rho(z-t)} dz, \quad (17)$$

where the ideal price index of utility is given by:

$$p_U(z) \equiv \Omega_U p(z)^\varepsilon [(1 - t_L)w(z)]^{1-\varepsilon}, \quad \Omega_U \equiv [\varepsilon^\varepsilon (1 - \varepsilon)^{1-\varepsilon}]^{-1} > 0. \quad (18)$$

By taking the total differential of lifetime utility (17) and using (18), we arrive at our measure of welfare change:

$$d\Lambda(0) = \frac{\tilde{X}(0)}{\rho} - \frac{\rho \tilde{p}_U(0) + h_1^* \tilde{p}_U(\infty)}{\rho(\rho + h_1^*)}, \quad \tilde{p}_U(z) = \varepsilon \tilde{p}(z) + (1 - \varepsilon) \tilde{w}(z). \quad (19)$$

The first term on the right-hand side of (19) denotes the welfare effect of the jump in full consumption to its new equilibrium value. The welfare effect owing to the transitional change of the utility price index is captured by the second term. To show the importance of the dynamic dimension of our analysis, we decompose the welfare effect into a static component $d\Lambda_S(0)$ and a dynamic component $d\Lambda_D(0)$. To obtain the static welfare effect, we eliminate physical capital accumulation from the model, so that physical capital becomes de facto a fixed factor. We model the fixed factor by setting $\chi_K \rightarrow \infty$, which implies $\bar{z} \rightarrow 0$.

Table 5 displays the short-run and long-run effects on instantaneous utility (denoted by $\tilde{U}(0)$ and $\tilde{U}(\infty)$, respectively, and $\tilde{U}(t) = \tilde{X}(t) - \tilde{p}_U(t)$) and the resulting change in lifetime utility $d\Lambda(0)$ (i.e., the present discounted value of utility). We again study the three scenarios set out in Table 4. In the benchmark scenario, instantaneous utility decreases on impact, recovers gradually over time, and eventually settles down at a higher steady-state level. Intuitively, the anticipated future decline in the wage rate—and the associated fall in full consumption—induces households to cut back on leisure consumption. During transition, labor supply falls as the wage rate decreases thereby decreasing composite consumption. Moreover, the utility price index is decreasing over time, reflecting a falling composite consumption price index and wage rate. Both the dynamic and the static component of the change in lifetime utility are positive, although the dynamic component is smaller than the static component.

In the scenario with exogenous labor supply [columns (3)–(4)], the increase in welfare is considerably larger, because the negative short-run effect on instantaneous utility disappears. Intuitively, the household no longer derives utility from leisure so that the distortion of the household's intertemporal labor supply decision cannot occur. In the scenario with Cobb-

Douglas production functions [columns (5)–(6)], the welfare change is also larger than in the benchmark case. The reason is that the intertemporal distortion of the import tariff is larger the higher is the substitutability of inputs in production. Therefore, in both alternative scenarios, especially the dynamic part of the welfare change increases compared to the benchmark case.

It is well known that the welfare effects of tax policy changes in an n th best setting depend crucially on pre-existing tax and tariff distortions. Therefore, we show the effect of changes in pre-existing tax and tariff rates on lifetime utility. Panel (a) of Figure 3 depicts the welfare change for different combinations of the consumption tax rate and the import tariff rate. In line with intuition, the welfare change depends positively on the initial import tariff rate and negatively on the initial consumption tax rate. The intersection of the welfare plane with the $d\Lambda(0) = 0$ plane indicates that the welfare change becomes negative if the pre-existing import tariff rate is small, or if the pre-existing consumption tax rate is high.

Panel (b) of the figure shows that the welfare change is negatively affected by the pre-existing labor income tax rate. Intuitively, high pre-existing labor income tax rates distort the relative price of consumption and leisure more than low tax rates, which makes the required increase in the revenue-neutral consumption tax rate more distortionary. Panel (b) also reveals that an increase in the pre-existing import tariff on capital goods has a negative effect on the welfare change. Intuitively, higher tariffs on imported capital goods decrease the size of the import-substitution sector and therefore counteract the effect of higher tariffs on imported consumption goods, which tend to increase the size of the import-substitution sector. Consequently, higher pre-existing tariffs on imported capital goods make pre-existing tariffs on imported consumption goods less harmful, leading to a smaller welfare gain of the cut in the import tariff rate on consumption goods. The welfare change turns negative at relatively high values of the pre-existing labor tax rate.

Panel (c) of Figure 3 presents the reform's welfare implications for various values of the intertemporal elasticity of labor supply and initial consumption tax rates. In line with the results in Table 5, we find that the welfare change depends negatively on the labor supply elasticity. In addition, the negative relationship between the labor supply elasticity and the welfare change is stronger for higher pre-existing consumption tax rates. The figure shows that combinations of a relatively high pre-existing consumption tax rate and a relatively high

intertemporal elasticity of labor supply may lead to a negative welfare effect.

Panel (d) of Figure 3 shows the dynamic welfare effect, which is obtained by subtracting the static welfare effect from the total welfare effect, for various values of the pre-existing import tariff rate on consumption goods and the mobility of physical capital, which is measured by \bar{z} . The absolute value of the dynamic welfare effect depends positively on capital mobility and converges to zero if capital mobility becomes low. The figure also shows a positive relationship between the pre-existing import tariff rate and the dynamic part of the welfare effect. The reason is that the import tariff positively affects the steady-state stock of physical capital; the decrease in the capital stock brought about by the tax-tariff reform is more advantageous if the capital stock is further above (or to a smaller extent below) its second-best optimum.

6 Conclusions

We build a micro-founded macroeconomic model of a developing small open economy to study the dynamic welfare and allocation effects of revenue-neutral trade liberalization. In particular, we analyze a tax-tariff reform strategy of decreasing the tariff rate on imported consumption goods and simultaneously changing the domestic consumption tax rate in such a way that the path of government revenue remains unaffected. Our model features two production sectors, imperfect physical capital mobility, endogenous labor supply, and two different tax and two tariff instruments. We solve the model analytically and provide a simulation analysis to quantify the effects of the reform.

We find that the reform increases aggregate output and aggregate employment in the short run, owing to an increase in labor supply. However, output and employment decrease in the long run, reflecting a fall in the physical capital stock. Output and employment in the import-substitution sector decrease, whereas output and employment in the export sector rise, more so in long run than in the short run. The gross volume of international trade (so-called market access), falls on impact and increases in the long run. Because human capital decreases on impact, instantaneous utility at the time of the shock goes down, causing the short-run welfare implications to differ from those found in the static literature. Instantaneous utility recovers during the transition and eventually reaches a higher long-run level than before the reform. However, for a plausible calibration of the model, lifetime utility is shown to increase,

which is induced by the dynamic net efficiency gain of the reform.

The sensitivity analysis shows that the increase in lifetime utility is robust to changes in pre-existing tax and tariff rates within the set of plausible parameter values for a typical developing country. Compared to exogenous labor supply, endogenous labor supply reduces the long-run welfare gain of the reform, because it exacerbates the distortion of the household's intertemporal labor supply decision. In terms of welfare losses, the harmfulness of the tariff rate on imported consumption goods increases with the size of the substitution elasticities between factors of production in both sectors.

We have not addressed the political economy aspects of tax-tariff reforms. Future research could try to fill this gap by introducing heterogeneity among households. In addition, to better capture the characteristics of developing countries, we would like to relax the assumption of perfect factor markets. Finally, it would be interesting to investigate how our results change for export taxes, which are a combination of a production tax and a consumption subsidy.

Appendix

This Appendix derives the quasi-reduced forms of the model conditional on the state variables (Section A.1) and studies the dynamic system (Section A.2).

A.1 Quasi-Reduced Forms

We express all endogenous variables of the model in terms of the state variables (\tilde{K} , \tilde{q} , \tilde{X} , \tilde{F}) and the tax policy instruments (\tilde{t}_C , $\tilde{\tau}_M$). In the following, we will drop time subscripts.

We combine (T1.5)–(T1.7) to determine the labor market equilibrium:

$$\begin{bmatrix} \tilde{L} \\ \tilde{L}_M \\ \tilde{L}_E \\ \tilde{w} \end{bmatrix} = \begin{bmatrix} \omega_L & -\omega_L^M & -\omega_L^E & 0 \\ 0 & \frac{\theta_K}{\sigma_M} & 0 & 1 \\ 0 & 0 & \frac{\theta_Z}{\sigma_E} & 1 \\ 1 & 0 & 0 & -\sigma_{LL} \end{bmatrix}^{-1} \begin{bmatrix} 0 \\ \frac{\theta_K}{\sigma_M} \tilde{K} + \tilde{\tau}_M \\ 0 \\ -\sigma_{LL} \tilde{X} \end{bmatrix}. \quad (\text{A.1})$$

In single equation form, labor market equilibrium implies

$$\tilde{L} = \frac{\sigma_{LL} \theta_K \theta_Z \omega_L^M}{\sigma_E \sigma_M |\Omega|} \tilde{K} - \frac{\sigma_{LL}}{|\Omega|} \left(\frac{\theta_K \omega_L^E}{\sigma_M} + \frac{\theta_Z \omega_L^M}{\sigma_E} \right) \tilde{X} + \frac{\sigma_{LL} \theta_Z \omega_L^M}{\sigma_E |\Omega|} \tilde{\tau}_M, \quad (\text{A.2})$$

$$\tilde{L}_M = \frac{\theta_K [\sigma_{LL} \theta_Z \omega_L + \sigma_E \omega_L^E]}{\sigma_M \sigma_E |\Omega|} \tilde{K} - \frac{\sigma_{LL} \theta_Z \omega_L}{\sigma_E |\Omega|} \tilde{X} + \frac{\sigma_{LL} \theta_Z \omega_L + \sigma_E \omega_L^E}{\sigma_E |\Omega|} \tilde{\tau}_M, \quad (\text{A.3})$$

$$\tilde{L}_E = -\frac{\theta_K \omega_L^M}{\sigma_M |\Omega|} \tilde{K} - \frac{\sigma_{LL} \theta_K \omega_L}{\sigma_M |\Omega|} \tilde{X} - \frac{\omega_L^M}{|\Omega|} \tilde{\tau}_M, \quad (\text{A.4})$$

$$\tilde{w} = \frac{\theta_K \theta_Z \omega_L^M}{\sigma_E \sigma_M |\Omega|} \tilde{K} + \frac{\sigma_{LL} \theta_K \theta_Z \omega_L}{\sigma_E \sigma_M |\Omega|} \tilde{X} + \frac{\theta_Z \omega_L^M}{\sigma_E |\Omega|} \tilde{\tau}_M, \quad (\text{A.5})$$

where $|\Omega| \equiv [\theta_K (\sigma_{LL} \theta_Z \omega_L + \sigma_E \omega_L^E) + \sigma_M \theta_Z \omega_L^M] (\sigma_M \sigma_E)^{-1} > 0$ denotes the absolute value of the determinant of the coefficient matrix on the right-hand side of (A.1).

By combining (T1.12)–(T1.15), we obtain quasi-reduced form expressions for consumption of both goods:

$$\tilde{C}_M = \frac{(\sigma_C - 1) \omega_C^M - \sigma_C \omega_C}{\omega_C} \tilde{\tau}_M - \tilde{t}_C + \tilde{X}, \quad (\text{A.6})$$

$$\tilde{C}_E = (\sigma_C - 1) \frac{\omega_C^M}{\omega_C} - \tilde{t}_C + \tilde{X}. \quad (\text{A.7})$$

The quasi-reduced form for government revenue is:

$$\tilde{T} = \xi_{TK} \tilde{K} + \xi_{TQ} \tilde{q} + \xi_{TX} \tilde{X} + \phi_{TC} \tilde{t}_C + \phi_{TM} \tilde{\tau}_M, \quad (\text{A.8})$$

which is obtained by substituting (T1.9)–(T1.10), (A.2)–(A.3), and (A.5)–(A.7) into (T1.17), where the revenue elasticities for \tilde{K} , \tilde{X} , and \tilde{q} are defined as:

$$\begin{aligned}\xi_{TK} &\equiv \frac{t_L \omega_L \theta_K \theta_Z \omega_L^M (\sigma_{LL} + 1)}{\sigma_E \sigma_M |\Omega|} - \frac{\tau_M \omega_L^M}{(1 - \theta_K)(1 + \tau_M)} \left[1 - \frac{(1 - \theta_K) \sigma_M \theta_Z \omega_L^M}{\sigma_E \sigma_M |\Omega|} \right] \\ &+ \frac{\tau_I}{1 + \tau_I} \omega_I, \\ \xi_{TX} &\equiv \frac{t_L \omega_L \sigma_{LL}}{|\sigma_E \sigma_M \Omega|} (\theta_K \theta_Z \omega_L - \theta_K \omega_L^E \sigma_E - \theta_Z \omega_L^M \sigma_M) + \frac{t_C \omega_C^E}{1 + t_C} \\ &+ \frac{t_C + \tau_M + t_C \tau_M}{(1 + t_C)(1 + \tau_M)} \omega_C^M + \frac{\tau_M}{1 + \tau_M} \frac{\omega_L^M \sigma_{LL} \theta_Z \omega_L}{\sigma_E |\Omega|}, \\ \xi_{TQ} &\equiv \frac{\tau_I}{1 + \tau_I} \frac{\omega_I}{\sigma_K},\end{aligned}$$

and the revenue elasticities for the tax policy instruments are:

$$\begin{aligned}\phi_{TC} &\equiv \frac{(1 + \tau_M) \omega_C^E + \omega_C^M}{(1 + \tau_M)(1 + t_C)}, \\ \phi_{TM} &\equiv \frac{t_L \omega_L \theta_Z \omega_L^M}{\sigma_E |\Omega|} (1 + \sigma_{LL}) + \frac{t_C + \tau_M + t_C \tau_M}{(1 + t_C)(1 + \tau_M)} \frac{(\sigma_C - 1) \omega_C^M - \sigma_C \omega_C}{\omega_C} \omega_C^M \\ &+ \frac{t_C}{1 + t_C} \frac{\omega_C^E \omega_C^M}{\omega_C} (\sigma_C - 1) - \frac{\tau_M}{1 + \tau_M} \omega_L^M \frac{[\sigma_{LL} \theta_Z \omega_L + \sigma_E \omega_L^E]}{\sigma_E |\Omega|} \\ &+ \left(\omega_C^M - \frac{1}{1 - \theta_K} \omega_L^M \right).\end{aligned}$$

By imposing $\tilde{T} = 0$, we obtain the endogenously determined time path of the consumption tax rate, which is given by (13) in the main text.

A.2 Dynamic System

A.2.1 Investment Subsystem

The investment system (14a) is obtained by substituting (T1.9)–(T1.10), and (A.3) into (T1.1)–(T1.2). The two non-zero elements in the Jacobian matrix Δ_I are:

$$\begin{aligned}\delta_{KQ} &\equiv \frac{r \omega_I}{\chi_K \omega_K} > 0, \\ \delta_{QK} &\equiv \frac{r (\omega_L^M)^2 \theta_K \theta_Z}{\sigma_E \sigma_M \omega_K |\Omega|} > 0,\end{aligned}$$

and the non-zero shock terms in the matrix Λ_I are given by:

$$\lambda_{QX} \equiv \frac{r\omega_L^M \omega_L \sigma_{LL} \theta_K \theta_Z}{\sigma_E \sigma_M \omega_K |\Omega|} > 0,$$

$$\lambda_{QM} \equiv \frac{r\omega_L^M}{(1-\theta_K)\omega_K} \left[\frac{(1-\theta_K)\theta_Z \omega_L^M}{\sigma_E |\Omega|} - 1 \right] < 0.$$

The eigenvalues of Δ_I are given by:

$$-h_1^* = \frac{1}{2} \left(r - \sqrt{4\delta_{KQ}\delta_{QK} + r^2} \right) < 0, \quad (\text{A.9})$$

$$r_1^* = \frac{1}{2} \left(r + \sqrt{4\delta_{KQ}\delta_{QK} + r^2} \right) = h_1^* + r > 0. \quad (\text{A.10})$$

Hence, the model has one positive (unstable) eigenvalue and one negative (stable) eigenvalue, so that the steady state is unique and saddle point stable. Furthermore, we have

$$\lim_{\chi_K \rightarrow 0} \delta_{KQ} = \infty \Rightarrow \lim_{\chi_K \rightarrow 0} h_1^* = \infty, \quad (\text{A.11})$$

$$\lim_{\chi_K \rightarrow \infty} \delta_{KQ} = 0 \Rightarrow \lim_{\chi_K \rightarrow \infty} h_1^* = 0. \quad (\text{A.12})$$

This completes the proof of part (i) of Proposition 1.

We use the Laplace transform method as set out in Judd (1982) to derive impulse-response functions for the key variables of the system. The Laplace transform is defined as $\mathcal{L}\{x, s\} \equiv \int_0^\infty x(z)e^{-sz}dz$, where s denotes the discount rate and \mathcal{L} is the Laplace transform operator. By taking the Laplace transform of (14a) and imposing $\tilde{K}(0) = 0$, we get:

$$\Gamma_I(s) \begin{bmatrix} \mathcal{L}\{\tilde{K}, s\} \\ \mathcal{L}\{\tilde{q}, s\} \end{bmatrix} = \Lambda_I \begin{bmatrix} \mathcal{L}\{\tilde{X}, s\} \\ \mathcal{L}\{\tilde{\tau}_M, s\} \end{bmatrix} + \begin{bmatrix} 0 \\ \tilde{q}(0) \end{bmatrix}, \quad (\text{A.13})$$

where $\Gamma_I(s) \equiv sI - \Delta_I$ and I is the identity matrix. Multiplying both sides of (A.13) by $\Gamma_I(s)^{-1}$ yields:

$$(s + h_1^*) \begin{bmatrix} \mathcal{L}\{\tilde{K}, s\} \\ \mathcal{L}\{\tilde{q}, s\} \end{bmatrix} = \frac{\text{adj } \Gamma_I(s)}{s - r_1^*} \begin{bmatrix} 0 \\ \tilde{q}(0) + \lambda_{QX}\mathcal{L}\{\tilde{X}, s\} + \lambda_{QM}\mathcal{L}\{\tilde{\tau}_M, s\} \end{bmatrix}, \quad (\text{A.14})$$

where we used Cramer's rule to get:

$$\Gamma_I(s)^{-1} = \frac{\text{adj } \Gamma_I(s)}{|\Gamma_I(s)|} = \frac{1}{(s - r_1^*)(s + h_1^*)} \text{adj } \Gamma_I(s). \quad (\text{A.15})$$

The adjoint matrix of $\Gamma_I(s)$ is given by:

$$\text{adj } \Gamma_I(s) \equiv \begin{bmatrix} s - r & \delta_{KQ} \\ \delta_{QK} & s \end{bmatrix}. \quad (\text{A.16})$$

Eliminating the positive root r_1^* that violates the transversality condition (10d) gives rise to the following condition:

$$\text{adj } \Gamma_I(r_1^*) \begin{bmatrix} 0 \\ \tilde{q}(0) + \lambda_{QX} \mathcal{L}\{\tilde{X}, s\} + \lambda_{QM} \mathcal{L}\{\tilde{\tau}_M, s\} \end{bmatrix} = \begin{bmatrix} 0 \\ 0 \end{bmatrix}. \quad (\text{A.17})$$

We investigate a one-off and permanent shock, so that $\tilde{\tau}_M(z) = \tilde{\tau}_M$ for all $z > 0$, which implies

$$\mathcal{L}\{\tilde{\tau}_M, s\} = \frac{\tilde{\tau}_M}{s}. \quad (\text{A.18})$$

Furthermore, it follows from $r = \rho$ and (5b) that $\tilde{X}(z) = \tilde{X}(0)$ for all $z > 0$ so that

$$\mathcal{L}\{\tilde{X}, s\} = \frac{\tilde{X}(0)}{s}. \quad (\text{A.19})$$

Therefore, condition (A.17) implies:

$$\tilde{q}(0) = -\frac{1}{r_1^*} \left(\lambda_{QX} \tilde{X}(0) + \lambda_{QM} \tilde{\tau}_M \right). \quad (\text{A.20})$$

By substituting (A.20) into the first and second row of (A.14), we get

$$\mathcal{L}\{\tilde{K}, s\} = -\frac{1}{s(s + h_1^*)} \frac{\delta_{KQ}}{r_1^*} \left(\lambda_{QX} \tilde{X}(0) + \lambda_{QM} \tilde{\tau}_M \right), \quad (\text{A.21})$$

$$\mathcal{L}\{\tilde{q}, s\} = -\frac{\lambda_{FQ}}{r_1^*} \frac{1}{s + h_1^*} \left(\lambda_{QX} \tilde{X}(0) + \lambda_{QM} \tilde{\tau}_M \right). \quad (\text{A.22})$$

We take the inverse Laplace transform of (A.21) and (A.22) to obtain the impulse-response functions for Tobin's q and for the stock of physical capital:

$$\tilde{q}(z) = -\frac{1}{r + h_1^*} \left[\lambda_{QM} \tilde{\tau}_M + \delta_{QX} \tilde{X}(0) \right] e^{-h_1^* z}, \quad (\text{A.23})$$

$$\tilde{K}(z) = \frac{\delta_{KQ}}{(r + h_1^*) h_1^*} \left[\lambda_{QM} \tilde{\tau}_M + \delta_{QX} \tilde{X}(0) \right] \left(1 - e^{-h_1^* z} \right) = \frac{\delta_{KQ}}{h_1^*} \tilde{q}(0) \left(1 - e^{-h_1^* z} \right), \quad (\text{A.24})$$

so that the stable eigenvalue $-h_1^*$ determines the convergence speed of the investment system.

A.2.2 Savings Subsystem

The savings system (14b) is obtained by substituting (T1.9)–(T1.11), (A.3), (A.6), (A.7) into (T1.3). The elements in the matrix Δ_S are given by:

$$\delta_{FX} \equiv \frac{r\omega_L\sigma_{LL} \left[\sigma_E\sigma_M |\Omega| \frac{\varepsilon}{1-\varepsilon} (1-t_L) + \omega_L\theta_K\theta_Z t_L + (1-t_L)(\sigma_E\theta_K\omega_L^E + \sigma_M\theta_Z\omega_L^M) \right]}{-\sigma_E\sigma_M |\Omega|} < 0,$$

$$\lambda_{FK} \equiv r \left[\frac{\omega_L^M}{1-\theta_K} \left(1 - \frac{(1-\theta_K)\theta_Z\omega_L^M}{\sigma_E |\Omega|} \right) - \frac{\theta_K\omega_L^M [\omega_L^E\sigma_E + t_L\omega_L\theta_Z(\sigma_{LL}+1)]}{\sigma_E\sigma_M |\Omega|} - \omega_I \right],$$

and the elements of Λ_S are:

$$\lambda_{FQ} \equiv -\frac{r\omega_I}{\sigma_K} < 0,$$

$$\lambda_{FM} \equiv \frac{r \{ |\Omega| \sigma_E + (1-\theta_K) [\sigma_{LL}(1-t_L) - t_L] \theta_Z \omega_L \} \omega_L^M}{\sigma_E(1-\theta_K) |\Omega|} > 0.$$

The eigenvalues of Δ_S are given by: $h_2^* = 0$ and $r_2^* = r > 0$. The zero root h_2^* implies that the savings system features a hysteretic steady state. Because there is exactly one strictly positive eigenvalue (r_2^*) and one forward-looking variable (\tilde{X}), the savings system is locally saddle point stable (Giavazzi and Wyplosz, 1985, p. 354). This proves part (ii) of Proposition 1.

We take the Laplace transform of (14b) and impose $\tilde{F}(0) = 0$ to get:

$$\Gamma_S(s) \begin{bmatrix} \mathcal{L}\{\tilde{X}, s\} \\ \mathcal{L}\{\tilde{F}, s\} \end{bmatrix} = \Lambda_I \begin{bmatrix} \mathcal{L}\{\tilde{K}, s\} \\ \mathcal{L}\{\tilde{q}, s\} \\ \mathcal{L}\{\tilde{\tau}_M, s\} \end{bmatrix} + \begin{bmatrix} \tilde{X}(0) \\ 0 \end{bmatrix}, \quad (\text{A.25})$$

where $\Gamma_S(s) \equiv sI - \Delta_S$. Multiplying both sides of (A.25) by $\Gamma_S(s)^{-1}$ yields:

$$\begin{bmatrix} \mathcal{L}\{\tilde{X}, s\} \\ \mathcal{L}\{\tilde{F}, s\} \end{bmatrix} = \frac{\text{adj } \Gamma_S(s)}{s(s-r)} \begin{bmatrix} \tilde{X}(0) \\ \lambda_{FK}\mathcal{L}\{\tilde{K}, s\} + \lambda_{FQ}\mathcal{L}\{\tilde{q}, s\} + \lambda_{FM}\mathcal{L}\{\tilde{\tau}_M, s\} \end{bmatrix}, \quad (\text{A.26})$$

where we again used Cramer's rule to get:

$$\Gamma_S(s)^{-1} = \frac{\text{adj } \Gamma_S(s)}{|\Gamma_S(s)|} = \frac{1}{s(s-r)} \text{adj } \Gamma_S(s). \quad (\text{A.27})$$

The adjoint matrix of $\Gamma_S(s)$ is given by:

$$\text{adj } \Gamma_S(s) \equiv \begin{bmatrix} s-r & 0 \\ \delta_{FX} & s \end{bmatrix}. \quad (\text{A.28})$$

Eliminating the positive root r that violates transversality condition (10d) gives rise to the following condition:

$$\text{adj } \Gamma_S(r) \begin{bmatrix} \tilde{X}(0) \\ \lambda_{FK} \mathcal{L}\{\tilde{K}, r\} + \lambda_{FQ} \mathcal{L}\{\tilde{q}, r\} + \lambda_{FM} \mathcal{L}\{\tilde{\tau}_M, r\} \end{bmatrix} = \begin{bmatrix} 0 \\ 0 \end{bmatrix}. \quad (\text{A.29})$$

By substituting (A.21) and (A.22) into the second row of (A.29) and using (A.18), we find:

$$-\left(\lambda_{FM} \tilde{\tau}_M + \delta_{FX} \tilde{X}(0)\right) = \frac{1}{r + h_1^*} \left[h_1^* \lambda_{FK} \tilde{K}(\infty) + r \lambda_{FQ} \tilde{q}(0) \right], \quad (\text{A.30})$$

where $\tilde{q}(0)$ and $\tilde{K}(\infty)$ are obtained by evaluating (A.23) at $z = 0$ and by taking the limit of (A.24) for $z \rightarrow \infty$, respectively. Together with (A.23) and (A.24), condition (A.30) can be solved for the jump in full consumption as a function of the change in the import tariff rate. The inverse Laplace transform of the first row of (A.26) gives:

$$\tilde{X}(z) = \tilde{X}(0), \quad (\text{A.31})$$

which confirms the constancy of \tilde{X} during the transition. We combine the second row of (A.26) with the second row of (A.29) to get:

$$\begin{aligned} \mathcal{L}\{\tilde{F}, s\} &= \frac{\lambda_{FK} \delta_{KQ}}{r_1^*} \frac{1}{r} \left[\frac{1}{(s + h_1^*)(r + h_1^*)} + \frac{1}{s(s + h_1^*)} \right] \left(\lambda_{QX} \tilde{X}(0) + \lambda_{QM} \tilde{\tau}_M \right) \\ &\quad + \frac{\lambda_{FQ}}{r_1^*} \frac{1}{(s + h_2^*)(r + h_2^*)} \left(\lambda_{QX} \tilde{X}(0) + \lambda_{QM} \tilde{\tau}_M \right) \\ &\quad + \frac{1}{sr} \left(\delta_{FX} \tilde{X}(0) + \lambda_{FM} \tilde{\tau}_M \right). \end{aligned} \quad (\text{A.32})$$

By taking the inverse Laplace transform of (A.32) and using (A.23) and (A.24), we obtain the impulse-response function for the stock of net foreign assets:

$$\begin{aligned} \tilde{F}(z) &= - \left[\left(\frac{1}{r} - \frac{e^{-h_1^* z}}{r + h_1^*} \right) \lambda_{FK} \tilde{K}(\infty) + \frac{e^{-h_1^* z}}{r + h_1^*} \lambda_{FQ} \tilde{q}(0) \right] \\ &\quad - \frac{1}{r} \left(\lambda_{FM} \tilde{\tau}_M + \delta_{FX} \tilde{X}(0) \right). \end{aligned} \quad (\text{A.33})$$

A.2.3 Value of Land

By substituting (T1.8) and (A.4) into (T1.4), we find the quasi-reduced form differential equation for the value of land:

$$\dot{\tilde{V}}_Z = r \tilde{V}_Z + \lambda_{ZK} \tilde{K} + \lambda_{ZX} \tilde{X} + \lambda_{ZM} \tilde{\tau}_M, \quad (\text{A.34})$$

with

$$\lambda_{ZK} \equiv \frac{r\omega_Z(1-\theta_Z)\theta_K\omega_L^M}{\sigma_E\sigma_M|\Omega|} > 0, \quad (\text{A.35})$$

$$\lambda_{ZX} \equiv \frac{r\omega_Z(1-\theta_Z)\sigma_{LL}\theta_K\omega_L}{\sigma_E\sigma_M|\Omega|} > 0, \quad (\text{A.36})$$

$$\lambda_{ZM} \equiv \frac{r\omega_Z(1-\theta_Z)\omega_L^M}{\sigma_E|\Omega|} > 0. \quad (\text{A.37})$$

The Laplace transform of (A.34) is given by:

$$(s-r)\mathcal{L}\{\tilde{V}_Z, s\} = \tilde{V}_Z(0) + \lambda_{ZK}\mathcal{L}\{\tilde{K}, s\} + \lambda_{ZK} + \mathcal{L}\{\tilde{X}, s\} + \lambda_{ZM}\mathcal{L}\{\tilde{\tau}_M, s\}. \quad (\text{A.38})$$

We substitute the Laplace transforms (A.18), (A.19), and (A.21) into (A.38) to obtain:

$$(s-r)\mathcal{L}\{\tilde{V}_Z, s\} = \tilde{V}_Z(0) - \frac{\lambda_{ZK}\delta_{KQ}}{r_1^*s(s+h_1^*)} \left(\lambda_{QX}\tilde{X}(0) + \lambda_{QM}\tilde{\tau}_M \right) + \frac{\lambda_{ZX}}{s}\tilde{X}(0) + \frac{\lambda_{ZM}}{s}\tilde{\tau}_M. \quad (\text{A.39})$$

Eliminating the unstable root r , we find the following condition for the jump in the value of land:

$$\tilde{V}_Z(0) = \frac{\lambda_{ZK}\delta_{KQ}}{r_1^*r(r+h_1^*)} \left(\lambda_{QX}\tilde{X}(0) + \lambda_{QM}\tilde{\tau}_M \right) - \frac{1}{r} \left(\lambda_{ZX}\tilde{X}(0) + \lambda_{ZM}\tilde{\tau}_M \right). \quad (\text{A.40})$$

Using (A.24) and combining (A.39) and (A.40), we obtain the impulse-response function for the value of land:

$$\tilde{V}_Z(z) = -\lambda_{ZK}\frac{h_1^*}{r+h_1^*}\tilde{K}(\infty) \left[\frac{1}{h_1^*}(1-e^{-h_1^*z}) + \frac{1}{r} \right] - \frac{1}{r} \left(\lambda_{ZX}\tilde{X}(0) + \lambda_{ZM}\tilde{\tau}_M \right). \quad (\text{A.41})$$

A.2.4 Utility Price Index

In order to derive (19) in the main text, we use the time path of the price index of utility

$$\tilde{p}_U(z) = \tilde{p}_U(\tau)e^{-h_2^*(z-\tau)} + \tilde{p}_U(\infty) \left(1 - e^{-h_2^*(z-\tau)} \right), \quad z \geq \tau, \quad (\text{A.42})$$

which is obtained by substituting (A.5), (A.24), and (T1.14)–(T1.15) into (T1.18).

Figure 1: Phase Diagrams: The Investment and Savings System

Panel (a): Investment System

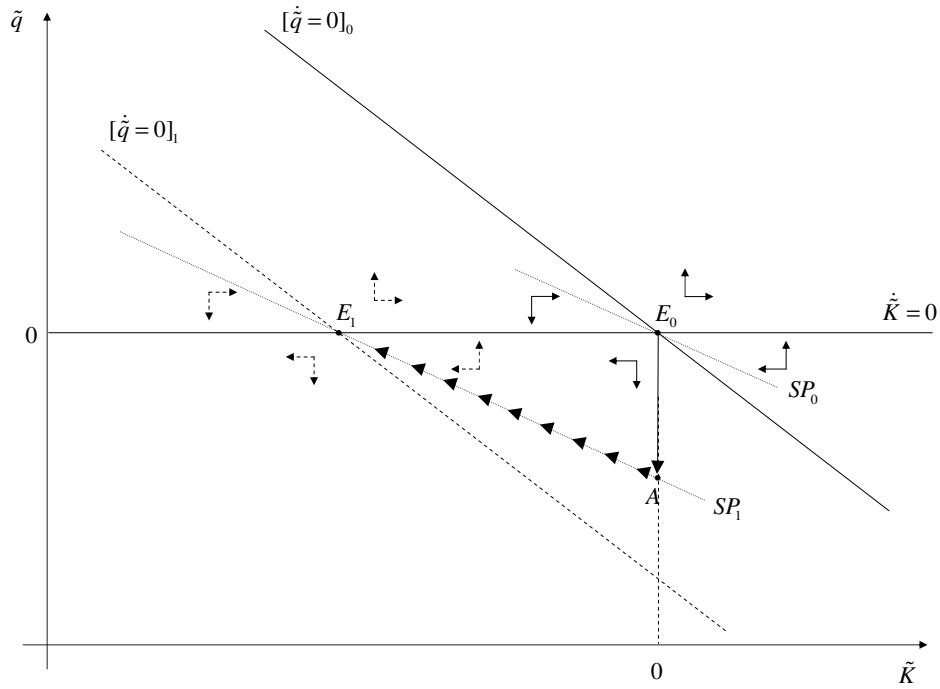

Panel (b): Savings System

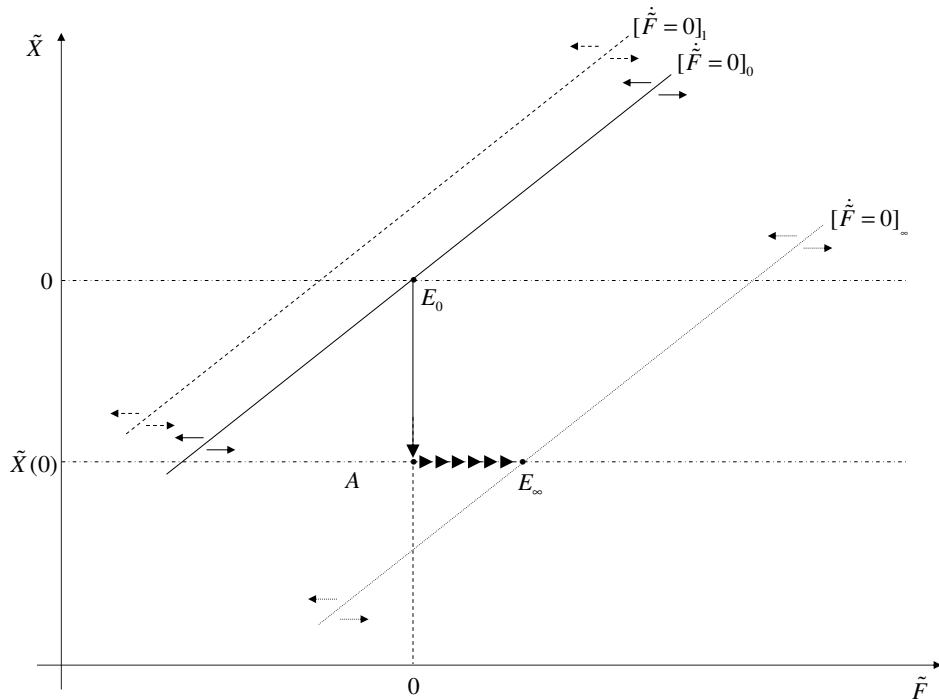

Notes: The model is non-recursive in the case of endogenous labor supply. The solution to the investment subsystem—which is depicted in Panel (a)—is conditional on $\tilde{X}(0)$ and Assumption 2. Panel (b) depicts the case in which $\lambda_{FQ}\tilde{q}(0) + \lambda_{FM}\tilde{\tau}_M > 0$ and $\tilde{X}(0) < 0$. Because the model is log-linearized, we can depict linear relationships and report the relative changes of variables on the axes. The initial equilibrium is located in the $(0, 0)$ point.

Figure 2: Aggregate and Sectoral Labor Market Equilibrium

Panel (a): Import-Substitution Sector

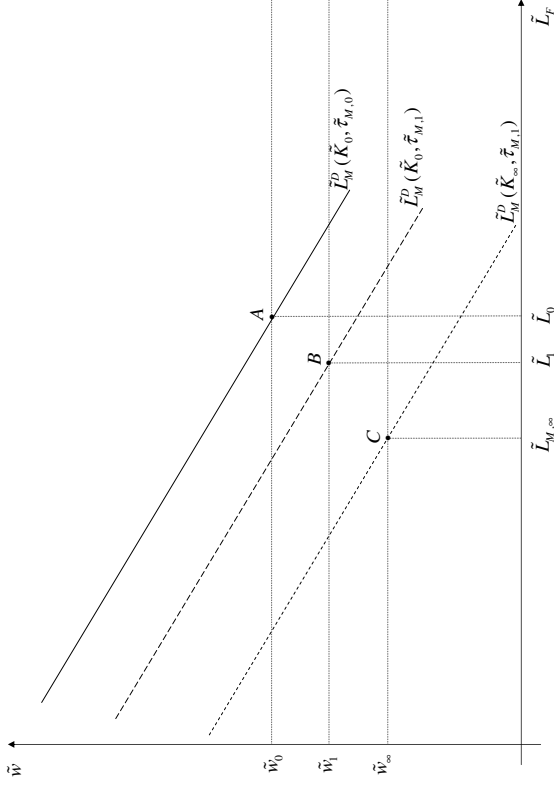

Panel (b): Agricultural Sector

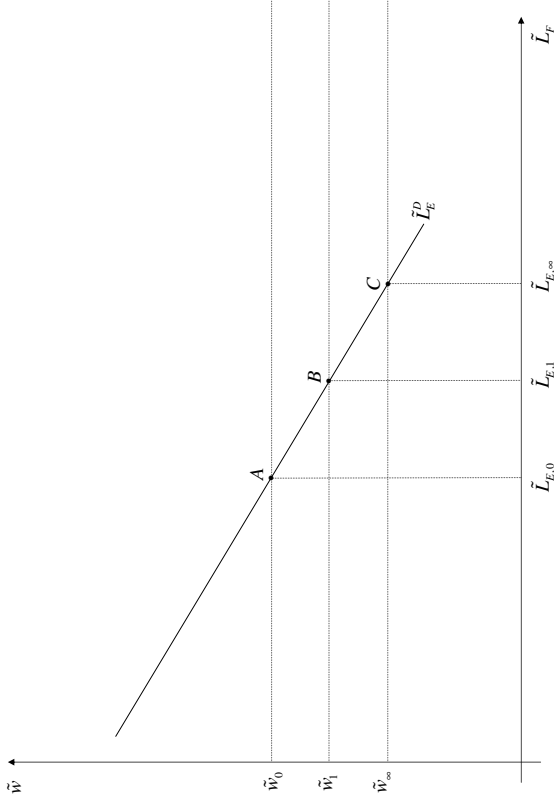

Panel (c): Aggregate Labor Market

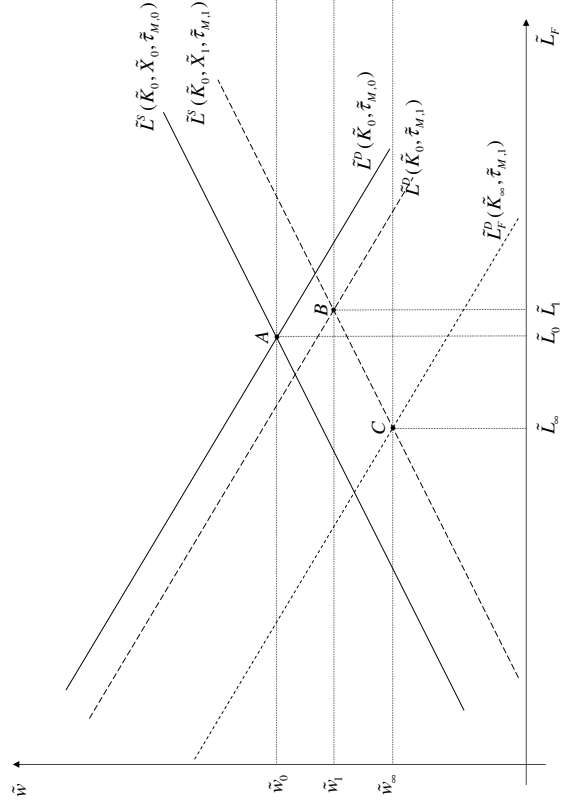

Notes: Panels (a) and (b) are based on equation (T1.7) and Panel (c) on equations (T1.5)–(T1.6). The dashed and dotted lines represent short-run and transitional responses, respectively. Panel (c) shows the case where the short-run labor supply dominates the downward shift in short-run labor demand.

Figure 3: Welfare Effects of Coordinated Tax-Tariff Reform

Panel (a): Different Pre-existing t_C and τ_M

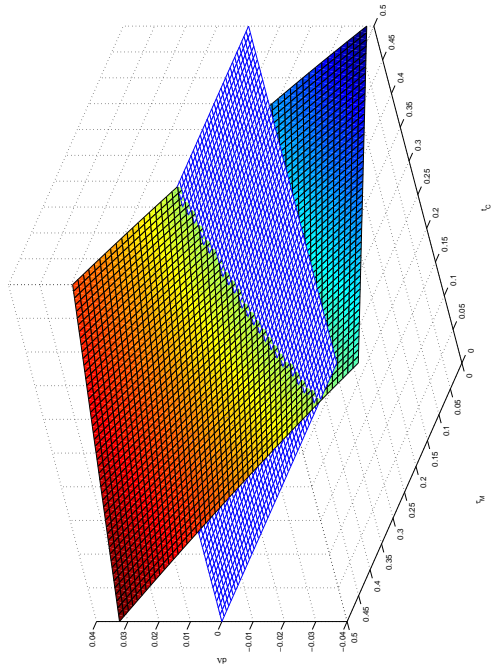

Different Pre-existing τ_I and t_L

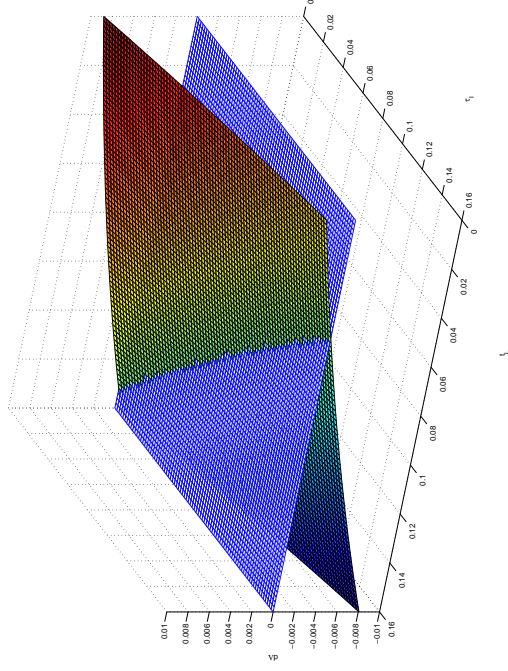

Panel (c): Different Pre-existing σ_{LL} and t_C

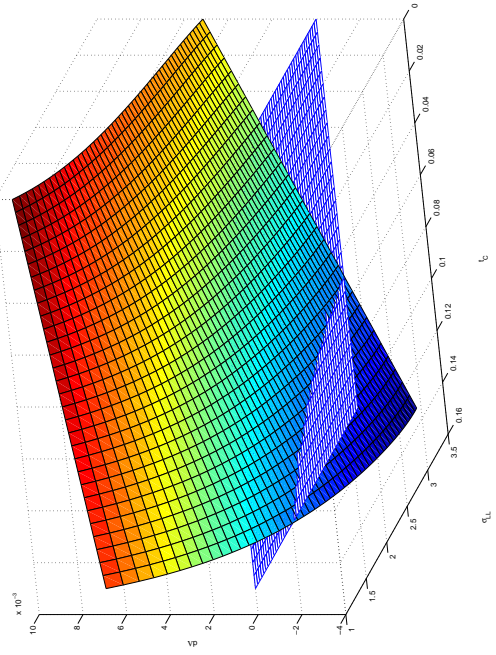

Panel (d): Different Pre-existing \bar{z} and τ_M (Dynamic Effect)

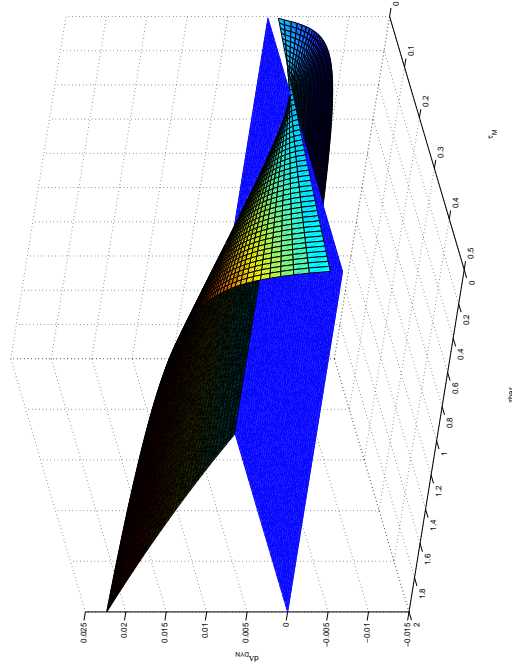

Notes: The other parameters are set at their benchmark values. The policy shock consists of $\bar{\tau}_M = -0.01$, where \bar{t}_C is being determined endogenously to keep government revenue unchanged. Panel (d) exhibits the dynamic welfare effect, which is the total welfare effect net of the static part.

Table 1: Summary of the Log-Linearized Model

 (a) *Dynamic Equations:*

$$\dot{\tilde{K}} = \frac{r\omega_I}{\omega_K} (\tilde{I} - \tilde{K}) \quad (\text{T1.1})$$

$$\dot{\tilde{q}} = r\tilde{q} - \frac{\theta_K}{1-\theta_K} \frac{r\omega_L^M}{\sigma_M\omega_K} (\tilde{Y}_M - \tilde{K} + \sigma_M\tilde{\tau}_M) \quad (\text{T1.2})$$

$$\begin{aligned} \dot{\tilde{F}} &= r \left[\tilde{F} + \frac{\omega_L^M}{(1-\theta_K)(1+\tau_M)} \tilde{Y}_M + \frac{\omega_L^E}{1-\theta_Z} \tilde{Y}_E \right] \\ &\quad - r \left[\frac{1}{1+t_C} \left(\frac{\omega_C^M}{1+\tau_M} \tilde{C}_M + \omega_C^E \tilde{C}_E \right) + \frac{\omega_I}{1+\tau_I} \tilde{I} \right] \end{aligned} \quad (\text{T1.3})$$

$$\dot{\tilde{V}}_Z = r (\tilde{V}_Z - \omega_Z \tilde{r}_Z) \quad (\text{T1.4})$$

 (b) *Factor Markets and Production:*

$$\tilde{L} = \sigma_{LL} (\tilde{w} - \tilde{X}) \quad (\text{T1.5})$$

$$\omega_L \tilde{L} = \omega_L^E \tilde{L}_E + \omega_L^M \tilde{L}_M \quad (\text{T1.6})$$

$$\tilde{w} = \tilde{\tau}_M + \frac{\theta_K}{\sigma_M} (\tilde{K} - \tilde{L}_M) = -\frac{\theta_Z}{\sigma_E} \tilde{L}_E \quad (\text{T1.7})$$

$$\tilde{r}_Z = \frac{1-\theta_Z}{\sigma_E} \tilde{L}_E \quad (\text{T1.8})$$

$$\tilde{q} = \chi_K (\tilde{I} - \tilde{K}) \quad (\text{T1.9})$$

$$\tilde{Y}_M = \theta_K \tilde{K} + (1-\theta_K) \tilde{L}_M \quad (\text{T1.10})$$

$$\tilde{Y}_E = (1-\theta_Z) \tilde{L}_E \quad (\text{T1.11})$$

 (c) *Consumption, Goods Prices, and Revenue:*

$$\tilde{C} = \tilde{X} - \tilde{p} \quad (\text{T1.12})$$

$$\tilde{C}_M = \sigma_C (\tilde{p} - \tilde{p}_M) + \tilde{C}, \quad \tilde{C}_E = \sigma_C (\tilde{p} - \tilde{p}_E) + \tilde{C} \quad (\text{T1.13})$$

$$\tilde{p} = \frac{\omega_C^M}{\omega_C} \tilde{p}_M + \frac{\omega_C^E}{\omega_C} \tilde{p}_E \quad (\text{T1.14})$$

$$\tilde{p}_M = \tilde{t}_C + \tilde{\tau}_M, \quad \tilde{p}_E = \tilde{t}_C \quad (\text{T1.15})$$

$$\begin{aligned} \tilde{T} &= t_L \omega_L (\tilde{w} + \tilde{L}) + \frac{\tau_I}{1+\tau_I} \omega_I \tilde{I} + \frac{t_C}{1+t_C} \omega_C^E \tilde{C}_E + \varepsilon_C \omega_X \tilde{t}_C \\ &\quad + \frac{t_C + \tau_M(1+t_C)}{(1+t_C)(1+\tau_M)} \omega_C^M \tilde{C}_M - \frac{\tau_M}{(1+\tau_M)} \omega_L^M \tilde{Y}_M + \left(\omega_C^M - \frac{1}{1-\theta_K} \omega_L^M \right) \tilde{\tau}_M \end{aligned} \quad (\text{T1.16})$$

 (d) *Portfolio Equilibrium and Welfare:*

$$\tilde{A} = \omega_K (\tilde{q} + \tilde{K}) + \tilde{V}_Z + \tilde{F} \quad (\text{T1.17})$$

$$\tilde{U} = \tilde{X} - \tilde{p}_U, \quad \tilde{p}_U = \varepsilon \tilde{p} + (1-\varepsilon) \tilde{w} \quad (\text{T1.18})$$

Notes: The following definitions are used: $\omega_C \equiv p_0 C_0 / Y_0$, $\omega_C^E \equiv (1+t_{C0})(C_E/Y)_0$, $\omega_C^M \equiv (1+t_{C0})(1+\tau_{M0})(C_M/Y)_0$, $\omega_I \equiv (1+\tau_{I0})I_0/Y_0$, $\omega_K \equiv (rqK)_0/Y_0$, $\omega_Z \equiv rz_0Z_0/Y_0$, $\omega_L \equiv (wL)_0/Y_0$, $\omega_L^i \equiv (wL_i)_0/Y_0$ for $i = \{M, E\}$, $\sigma_{LL} \equiv (1-L_0)/L_0$, and $\chi_K \equiv -(I_0/K_0)(\Psi''/\Psi') > 0$, where $Y_0 \equiv p_0 C_0 + p_{I0} I_0 - r F_0$ denotes steady-state GDP valued at market prices. A tilde ($\tilde{\cdot}$) denotes a relative change, for example, $\tilde{C}(z) \equiv dC(z)/C_0$. Time derivatives of variables are generally defined as $\dot{\tilde{X}}(z) \equiv d\tilde{X}(z)/X_0$.

Table 2: The Parameter Values in the Benchmark Scenario

Description	Parameter	Value	Source
<i>Tax policy parameters</i>			
Consumption tax rate	t_C	0.090	Gordon and Li (2009)
Labor income tax rate	t_L	0.070	Gordon and Li (2009)
Import tariff rate on capital goods	τ_I	0.075	Gordon and Li (2009)
Import tariff rate on consumption goods	τ_M	0.150	Gordon and Li (2009)
<i>Income shares</i>			
Labor income share in M sector	θ_K	0.300	Gollin (2002)
Labor income share in E sector	θ_Z	0.500	Valentinyi and Herrendorf (2008)
<i>Technology</i>			
Weight given to capital in M sector	α_M	0.500	Data: World Bank (2010)
Weight given to land in E sector	α_E	0.500	Data: World Bank (2010)
Elasticity of substitution in M sector	σ_M	0.500	Chirinko (2008)
Elasticity of substitution in E sector	σ_E	0.300	Salhofer (2000)
Land (fixed)	Z	0.200	Data: World Bank (2010)
<i>Capital accumulation</i>			
Rate of interest	r	0.050	Mendoza (1995) ^a
Rate of depreciation	δ	0.100	Mendoza (1995)
Adjustment cost parameter	\bar{z}	2.000	Mendoza (1991)
<i>Preferences^b</i>			
Weight given to M goods	γ	0.800	Data: World Bank (2010)
Elasticity of substitution in consumption	σ_C	0.500	Data: World Bank (2010)
Intertemporal labor supply elasticity	σ_{LL}	2.250	Mendoza (1991) and data from the Conference Board (2010)
Weight given to consumption	ε	0.475	Data: World Bank (2010)

Notes: ^aWe chose a slightly higher value than Mendoza (1995). ^bThe pure rate of time preference is equal to the rate of interest in the steady state and is therefore not reported separately.

Table 3: Implied Shares, Parameters, and Ratios in the Benchmark Scenario

Description	Parameter	Value
Productivity index of M sector	Ω_M	0.81
Productivity index of E sector	Ω_E	1.82
Capital-output ratio of M sector	K/Y_M	2.06
Capital-output ratio of overall economy	K/Y	0.52
GDP share of return on financial wealth	ω_A	0.31
GDP share of composite consumption	ω_C	0.92
GDP share of consumption good E	ω_C^E	0.29
GDP share of consumption good M	ω_C^M	0.63
GDP share of net foreign assets	ω_F	-0.59
GDP share of investment	ω_I	0.05
GDP share of capital income	ω_K	0.02
GDP share of total labor income	ω_L	0.48
GDP share of labor income of M sector	ω_L^M	0.17
GDP share of labor income of E sector	ω_L^E	0.32
GDP share of government revenue	ω_T	0.16
GDP share of imports	ω_{IM}	0.41
GDP share of exports	ω_{EX}	0.40
Revenue share of consumption tax	ω_C^T	0.48
Revenue share of labor income tax	ω_L^T	0.22
Revenue share of import tariff on I	ω_I^T	0.02
Revenue share of import tariff on C_M	ω_M^T	0.28
GDP share of land rentals	ω_Z	0.32

Notes: The following definitions are used: $\omega_{IM} = [p_{M0}(C_{M0} - Y_{M0}) + p_{M0}I_0]/Y_0$, $\omega_{EX} = p_{E0}(Y_{E0} - C_{E0})/Y_0$, $\omega_F \equiv F_0/Y_0$, $\omega_C^T \equiv t_{C0}[C_{E0} + (1 + \tau_{M0})C_{M0}]/T_0$, $\omega_L^T \equiv t_{L0}w_0L_0/T_0$, $\omega_I^T \equiv \tau_{I0}I_0/T_0$, and $\omega_M^T \equiv \tau_{M0}(C_{M0} - Y_{M0})/T_0$, where $Y_0 \equiv p_0C_0 + p_{I0}I_0 - rF_0$ denotes steady-state GDP valued at market prices. The other shares are defined in Table 1.

Table 4: Short-Run and Long-Run Allocation Effects

	$\sigma_{LL} = 2.25$		$\sigma_{LL} = 0$		$\sigma_E = \sigma_M = 1$	
	0	∞	0	∞	0	∞
	(1)	(2)	(3)	(4)	(5)	(6)
<i>Wealth</i>						
\tilde{A}	0.468	0.671	0.490	0.532	0.443	0.723
\tilde{H}	-2.287	-2.489	-0.723	-0.766	-2.209	-2.489
\tilde{F}	0.000	0.323	0.000	0.064	0.000	0.507
\tilde{K}	0.000	-6.402	0.000	-2.306	0.000	-10.909
\tilde{q}	-0.799	0.000	-0.546	0.000	-1.107	0.000
\tilde{V}_Z	0.492	0.535	0.506	0.535	0.475	0.535
<i>Labor market</i>						
\tilde{L}_M	-0.444	-5.687	-0.668	-1.592	-1.271	-9.495
\tilde{L}_E	0.440	0.857	0.360	0.857	1.217	2.829
\tilde{L}	0.131	-1.433	0.000	0.000	0.346	-1.485
\tilde{w}	-0.733	-1.429	-0.599	-1.429	-0.615	-1.429
<i>Production</i>						
\tilde{Y}_M	-0.311	-5.902	-0.467	-1.806	-0.890	-9.919
\tilde{Y}_E	0.220	0.429	0.180	0.429	0.609	1.414
\tilde{Y}	0.087	-1.158	0.018	-0.132	0.233	-1.426
<i>Consumption</i>						
\tilde{C}_M	-0.542	-0.368	0.178	0.238	-0.504	-0.197
\tilde{C}_E	-1.042	-0.868	-0.322	-0.262	-1.004	-0.697
\tilde{C}	-0.701	-0.527	0.019	0.079	-0.663	-0.356
\tilde{p}	-0.091	-0.265	-0.241	-0.301	-0.106	-0.413
<i>Investment</i>						
\tilde{I}	-16.379	-6.402	-11.188	-2.306	-22.704	-10.909
<i>Market access</i>						
\tilde{IM}	-1.115	0.920	-0.376	0.466	-1.283	1.789
\tilde{EX}	0.497	0.597	0.234	0.402	0.776	1.282
$\tilde{IM} + \tilde{EX}$	-0.618	1.518	-0.142	0.868	-0.508	3.071
<i>Fiscal sector</i>						
\tilde{t}_C	0.591	0.417	0.441	0.381	0.576	0.269

Notes: Tildes denote relative changes, except for IM , EX , and t_C where we define $\tilde{IM} = dIM/Y_0^*$, $\tilde{EX} = dEX/Y_0^*$, and $\tilde{t}_C = dt_C/(1+t_C)$. Y_0^* denotes aggregate steady-state output at world market prices. All parameters are set at their benchmark values in columns (1)–(2). Columns (3)–(4) set $\varepsilon = 1$, so that labor supply is exogenous (i.e., $\sigma_{LL} = 0$). Columns (5)–(6) correspond to Cobb-Douglas production functions, that is, $\sigma_E = \sigma_M = 1$. Note that columns (3) and (5) have been recalibrated (via adjustments in the stock of land) to arrive at the benchmark steady state. The policy shock consists of $\tilde{\tau}_M = -0.01$, where \tilde{t}_C is being determined endogenously to keep government revenue unchanged.

Table 5: Welfare Effects

	$\sigma_{LL} = 2.25$		$\sigma_{LL} = 0$		$\sigma_E = \sigma_M = 1$	
	0	∞	0	∞	0	∞
	(1)	(2)	(3)	(4)	(5)	(6)
\tilde{X}	-0.791	-0.791	-0.222	-0.222	-0.769	-0.769
\tilde{p}_U	-0.428	-0.876	-0.241	-0.301	-0.373	-0.946
\tilde{U}	-0.363	0.084	0.019	0.079	-0.396	0.177
$d\Lambda$	0.190	-	1.418	-	1.282	-
$d\Lambda_S$	0.176	-	0.706	-	0.463	-
$d\Lambda_D$	0.014	-	0.712	-	0.819	-

Notes: Using equation (1), we can derive $\tilde{U}(t) = \tilde{X}(t) - \tilde{p}_U(t)$ and $d\Lambda(0)$, where $d\Lambda(0)$ denotes the change in total lifetime utility, $d\Lambda_S(0)$ denotes the change in the static component, and $d\Lambda_D(0)$ is the change in the dynamic component. All parameters are set at their benchmark values in columns (1)–(2). Columns (3)–(4) set $\varepsilon = 1$, so that labor supply is exogenous (i.e., $\sigma_{LL} = 0$). Columns (5)–(6) correspond to Cobb-Douglas production functions, that is, $\sigma_E = \sigma_M = 1$. The policy shock consists of $\tilde{\tau}_M = -0.01$, where \tilde{t}_C is being determined endogenously to keep government revenue unchanged.

References

- ABE, K. (1995): “The Target Rates of Tariff and Tax Reform,” *International Economic Review*, 36, 875–885.
- BACKUS, D. K., P. J. KEHOE, AND F. E. KYDLAND (1994): “Dynamics of the Trade Balance and the Terms of Trade: The J-Curve?,” *American Economic Review*, 84, 84–103.
- BAUNSGAARD, T., AND M. KEEN (2010): “Tax Revenue and (or?) Trade Liberalization,” *Journal of Public Economics*, 94, 563–577.
- BROCK, P. L., AND S. J. TURNOVSKY (1993): “The Growth and Welfare Consequences of Differential Tariffs,” *International Economic Review*, 34, 765–794.
- CHIRINKO, R. (2008): “ σ : The Long and Short of It,” *Journal of Macroeconomics*, 30, 671–686.
- DE SOTO, H. (2001): “The Mystery of Capital,” *Finance & Development*, 38, 1.
- DENNIS, B. N., AND T. ISCAN (2007): “Productivity Growth and Agricultural Out-Migration in the United States,” *Structural Change and Economic Dynamics*, 18, 5274.
- EBRILL, L., M. KEEN, J.-P. BODIN, AND V. SUMMERS (2001): *The Modern VAT*. International Monetary Fund, Washington D.C.
- EMRAN, M. S., AND J. E. STIGLITZ (2005): “On Selective Indirect Tax Reform in Developing Countries,” *Journal of Public Economics*, 89, 599–623.
- FUKUSHIMA, T. (1979): “Tariff Structure, Non-Traded Goods and the Theory of Piecemeal Policy Recommendations,” *International Economic Review*, 20, 427–435.
- GIAVAZZI, F., AND C. WYPLOSZ (1985): “The Zero Root Problem: A Note on the Dynamic Determination of the Stationary Equilibrium in Linear Models,” *Review of Economic Studies*, 52, 353–357.
- GOLLIN, D. (2002): “Getting Income Shares Right,” *Journal of Political Economy*, 110, 458–474.

- GORDON, R., AND W. LI (2009): “Tax Structure in Developing Countries: Many Puzzles and a Possible Explanation,” *Journal of Public Economics*, 93, 855–866.
- GREENWOOD, J., Z. HERCOWITZ, AND G. W. HUFFMAN (1988): “Investment, Capacity Utilization, and the Real Business Cycle,” *American Economic Review*, 78, 402–417.
- HAQUE, M. E., AND A. MUKHERJEE (2005): “On the Revenue Implications of Trade Liberalization Under Imperfect Competition,” *Economics Letters*, 88, 27–31.
- HATTA, T. (1977): “A Recommendation for a Better Tariff Structure,” *Econometrica*, 45, 1859–1869.
- HATZIPANAYOTOU, P., M. S. MICHAEL, AND S. M. MILLER (2004): “Win-Win Indirect Tax Reform: A Modest Proposal,” *Economics Letters*, 44, 147–51.
- HEIJDRA, B. J. (1998): “Fiscal Policy Multipliers: The Role of Monopolistic Competition, Scale Economies, an Intertemporal Substitution in Labor Supply,” *International Economic Review*, 39, 659–696.
- INTERNATIONAL MONETARY FUND (2011): “Revenue Mobilization in Developing Countries,” IMF Policy Paper, IMF, Fiscal Affairs Department, Washington, D.C.
- JUDD, K. L. (1982): “An Alternative to Steady-State Comparisons in Perfect Foresight Models,” *Economics Letters*, 10, 55–59.
- KEEN, M., AND J. E. LIGTHART (2002): “Coordinating Tariff Reductions and Domestic Tax Reform,” *Journal of International Economics*, 56, 407–425.
- (2005): “Cordinating Tariff Reduction and Domestic Tax Reform under Imperfect Competition,” *Review of International Economics*, 13, 385–390.
- KIMBALL, M. S., AND M. D. SHAPIRO (2008): “Labor Supply: Are the Income and Substitution Effects Both Large or Both Small?,” NBER Working Paper No. 14208, National Bureau of Economic Research, Cambridge, MA.
- KING, R. G., C. I. PLOSSER, AND S. T. REBELO (1988): “Production, Growth and Business Cycles: I. The Basic Neoclassical Model,” *Journal of Monetary Economics*, 21, 195–232.

- KREICKEMEIER, U., AND P. RAIMONDOS-MØLLER (2008): “Tariff-Tax Reforms and Market Access,” *Journal of Development Economics*, 87, 85–91.
- LIGHTHART, J. E., AND G. C. VAN DER MEIJDEN (2010): “Coordinated Tax-Tariff Reforms, Informality, and Welfare Distribution,” CentER Discussion Paper No. 2010-61, Tilburg University, Tilburg.
- LIPSEY, R., AND K. LANCASTER (1957): “The General Theory of Second Best,” *Review of Economic Studies*, 24, 11–32.
- MENDOZA, E. G. (1991): “Real Business Cycles in a Small-Open Economy,” *American Economic Review*, 81, 797–818.
- (1995): “The Terms of Trade, the Real Exchange Rate, and Economic Fluctuations,” *International Economic Review*, 36, 101–137.
- MICHAEL, S., P. HATZIPANAYOTOU, AND S. M. MILLER (1993): “Integrated Reforms of Tariffs and Consumption Taxes,” *Journal of Public Economics*, 52, 417–428.
- NAITO, T. (2006a): “Growth, Revenue, and Welfare Effects of Tariff and Tax Reform: Win-Win-Win Strategies,” *Journal of Public Economics*, 90, 1263–1280.
- (2006b): “Tariff and Tax Reform: Dynamic Implications,” *Journal of International Economics*, 68, 504–517.
- PRESCOTT, E. C. (2006): “Nobel Lecture: The Transformation of Macroeconomic Policy and Research,” *Journal of Political Economy*, 114, 203–235.
- SALHOFER, K. (2000): “Elasticities of Substitution and Factor Supply Elasticities in European Agriculture: A Review of Past Studies,” Discussion paper No. 83-w, Department of Economics and Social Sciences, University of Natural Resources and Life Sciences, Vienna.
- THE CONFERENCE BOARD (2011): *Total Economy Database*. The Conference Board, New York.
- TURNOVSKY, S. J. (2011): “On the Role of Small Models in Macrodynamics,” *Journal of Economic Dynamics and Control*, 35, 1605–1613.

TURNOVSKY, S. J., AND M. A. BASHER (2009): “Fiscal Policy and the Structure of Production in a Two-Sector Developing Economy,” *Journal of Development Economics*, 88, 205–216.

UZAWA, H. (1969): “Time Preference and the Penrose Effect in a Two-Class Model of Economic Growth,” *Journal of Political Economy*, 77, 628–652.

VALENTINYI, A., AND B. HERRENDORF (2008): “Measuring Factor Income Shares at the Sectoral Level,” *Review of Economic Dynamics*, 11, 820–835.

WORLD BANK (2010): *World Development Indicators*. World Bank, Washington, D.C.